

1336-Series Drives to PowerFlex 750-Series Drives



 Allen-Bradley •

Rockwell Software

Rockwell
Automation

1336Plus 1336PlusII 1336Impact



POWERFLEX 750 SERIES

POWER CONNECTIONS TB1 ON 1336PLUS

Figure 2.2
Terminal Block TB1

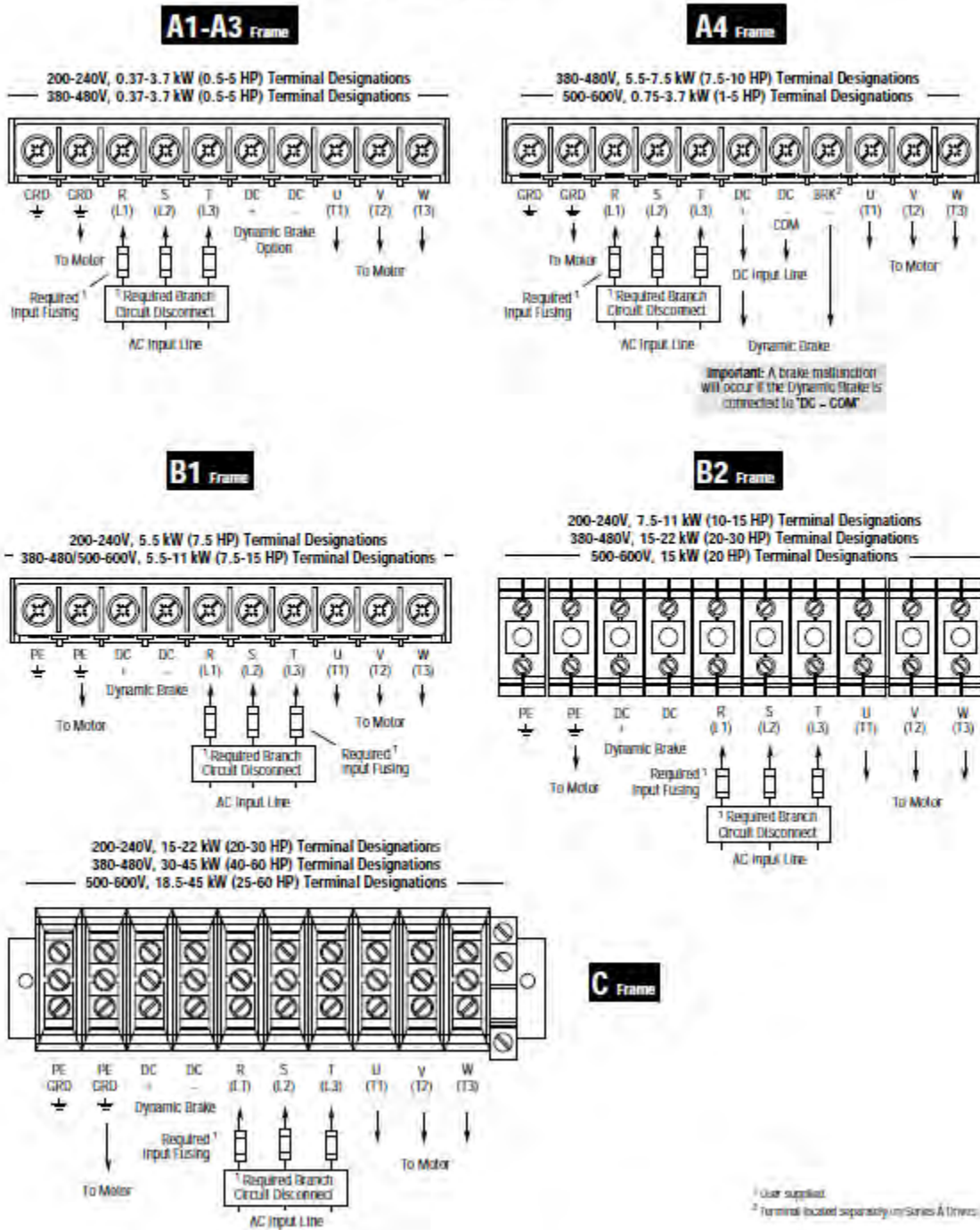

TB2 ANALOG SIGNALS AND RELAY FEEDBACK

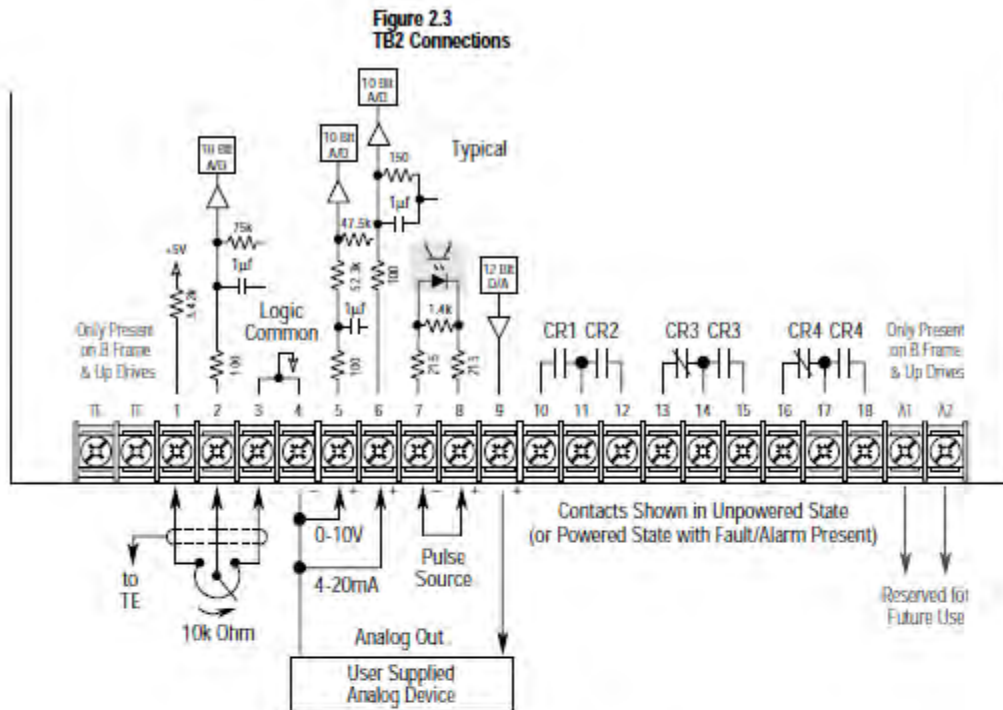

**Table 2.G
Terminal Block TB2 Specifications**

Terminal	Signal	
TE	True Earth – Shield Termination	
1, 2, 3	External Speed Pot. or Analog Trim Pot. (10k ohm pot. required) ²	
4	Signal Common	
5	0-10V DC Input ²	Input Impedance = 100k ohms
6	4-20mA Input ²	Input Impedance = 250 ohms
7, 8	Pulse Input for Frequency Ref. ⁴	Refer to <i>Pulse Input</i> on the following page
9	Analog Output ¹ A Frame Drives	Jumper JP1 to select 0-10V DC output ⁵ Jumper JP2 to select 0-20mA output ⁶
	Analog Output ¹ B Frame Drives and Up	Jumper J5 selects output pins 1-2 = 0-20mA ⁶ pins 3-4 = 0-10V DC ⁵
10, 11	CR1 Programmable Contact	Resistive Rating = 115V AC/30V DC, 5.0A Inductive Rating = 115V AC/30V DC, 2.0A
11, 12	CR2 Programmable Contact <i>Firmware Versions 4.01 & Up</i>	
	CR2 Run Contact <i>Firmware Versions below 4.01</i>	
13, 14 14, 15	CR3 Programmable Contact <i>Firmware Versions 4.01 & Up</i> CR3 Fault & Fault NOT Contact ³ <i>Firmware Versions below 4.01</i>	
16, 17 17, 18	CR4 Programmable Contact <i>Firmware Versions 4.01 & Up</i>	
	CR4 Alarm & Alarm NOT Contact <i>Firmware Versions below 4.01</i>	
A1, A2	Reserved for Future Use	

- ¹ Refer to the IO Config group parameters for analog scaling.
- ² Refer to the [Maximum Speed] parameter on page 5-45.
- ³ Refer to Chapter 6 for contact description.
- ⁴ Not available if Encoder Feedback option is used.
- ⁵ Minimum Load Impedance:
A Frame drives = 3.5k ohms
B Frame drives & Up = 1.5k ohms.
Recommended load for all frames = 10k ohms.
- ⁶ Maximum Load Impedance:
A Frame drives = 260 ohms
B Frame drives & Up = 315 ohms

TB3 DIGITAL INPUTS FOR 1336

Figure 2.5
Input Mode Selection & Typical TB3 Connections

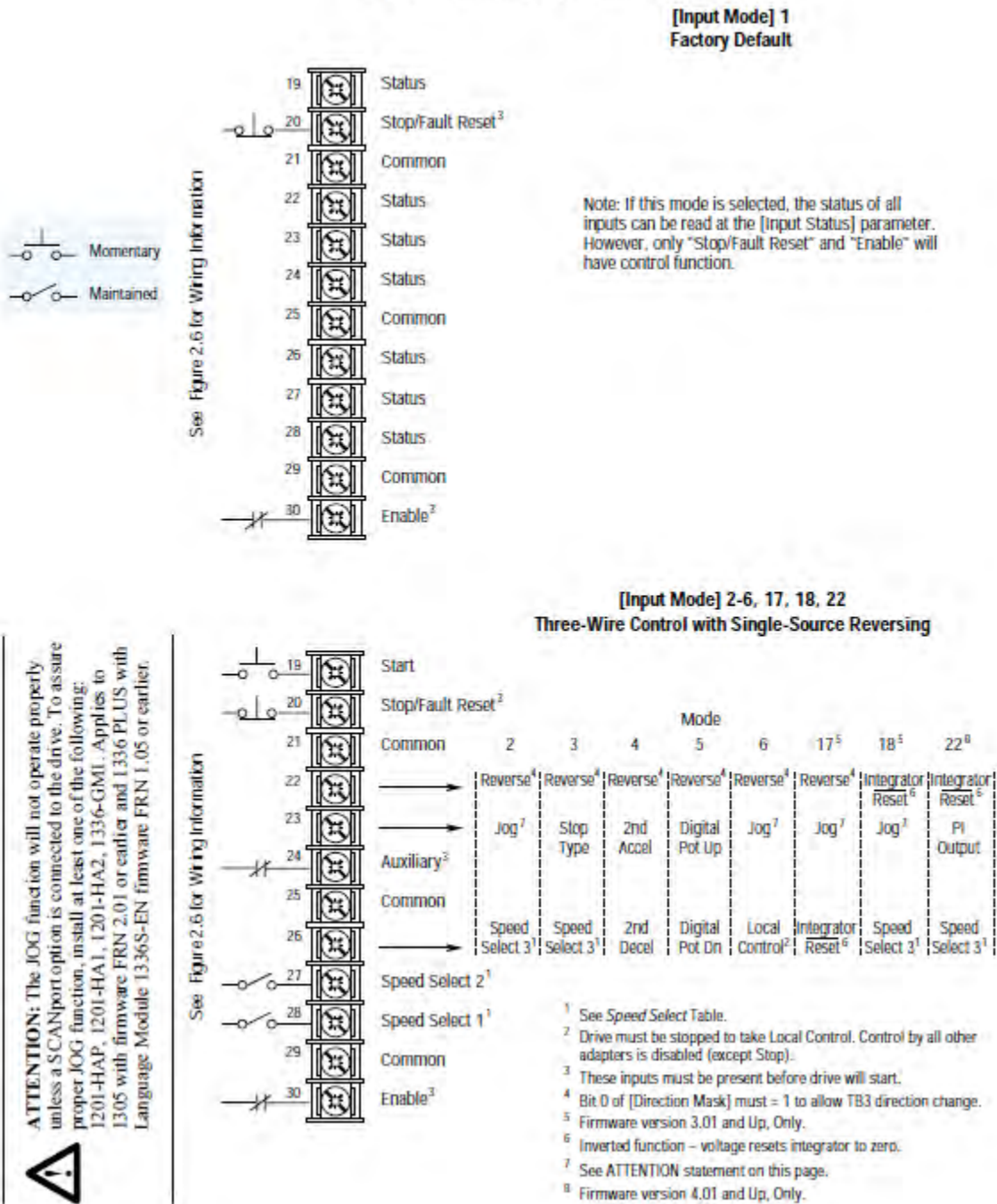

ATTENTION: The JOG function will not operate properly unless a SCANport option is connected to the drive. To assure proper JOG function, install at least one of the following: 1201-HAP, 1201-HA1, 1201-HA2, 1336-GM1. Applies to 1305 with firmware FRN 2.01 or earlier and 1336 PLUS with Language Module 1336S-EN firmware FRN 1.05 or earlier.



See Figure 2.6 for Wiring Information

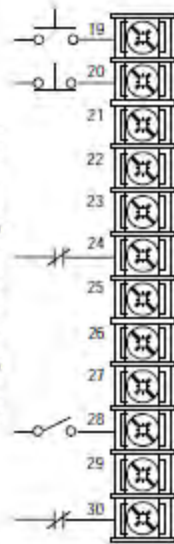

[Input Mode] 7-11, 19, 23 Three-Wire Control with Multi-Source Reversing

	Mode						
	7	8	9	10	11	19 ^E	23 ^E
Reverse ⁴	Reverse ⁴	Reverse ⁴	Digital Pot Up	Reverse ⁴	1st Accel	Reverse ⁴	Reverse ⁴
Forward ⁴	Forward ⁴	Forward ⁴	Digital Pot Dn	Forward ⁴	2nd Accel	Forward ⁴	Forward ⁴
Jog ⁷	Speed Select 3	Speed Select 3	Speed Select 3	Digital Pot Up	1st Decel	Integrator Reset ⁶	Integrator Reset ⁶
Speed Select 2 ²	Speed Select 2	Speed Select 2	Speed Select 2	Digital Pot Dn	2nd Decel	Speed Select 2	PI Output

[Input Mode] 12-16, 20, 21, 24 Two-Wire Control, Single-Source Control

See ATTENTION statement below

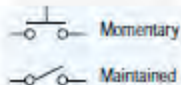

See Figure 2.6 for Wiring Information

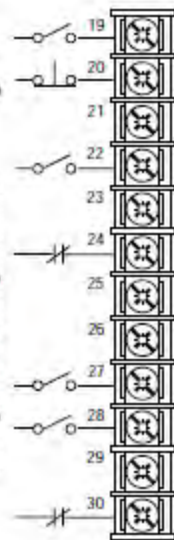

	Mode							
	12	13	14	15	16	20 ^E	21 ^E	24 ^E
Local Control ²	Local Control ²	Stop Type	2nd Accel	Digital Pot Up	Local Control ²	Local Control ²	Jog ⁷	PI Output
Speed Select 3 ³	Speed Select 3 ³	Speed Select 3 ³	2nd Decel	Digital Pot Dn	Stop Type	Integrator Reset ⁶	Speed Select 3 ³	Integrator Reset ⁶



Two wire control uses maintained Run contacts that act as both Run (closed) and Stop (open) devices. Opening the Stop contact (terminal 20) will stop the drive. If this contact is reclosed, any fault will be reset. If a valid Start command is still present, the drive will restart.

If a three wire device (i.e. HIM) is also used, pressing the HIM Stop key will also stop the drive. Releasing the Stop key will clear any faults that are present, but the drive will not restart without cycling the Start contact.

KEY TAKEAWAYS WHEN MODERNIZING TO PF750

- 1) TB1 IS POWER CONNECT 3 PHASE IN AND 3 PHASE OUT. TB1 ON THE 1336PLUS IS FIXED AND SO IS THE POWER TERMINALS ON PF750.
- 2) TB2 ARE THE ANALOG INPUTS AND RELAY OUTPUTS ON THE DRIVE. THE 1336PLUS HAS A FIXED TERMINAL CONFIGURATION AS SHOWN ABOVE FOR TB2. THE 1336PLUSII HAS MANY CONFIGURATIONS AND PORTS FOR THE ANALOG. YOU WILL NEED TO IDENTIFY THE GALVANICALLY ISOLATED CARDS FOR PROPER TRANSFORMATION. ON FAME "A" DRIVES THESE 1336-LA CARDS MAY BE LOCATED BEHIND THE HIM(KEYPAD).
- 3) TB3 HAS MANY CONFIGURATIONS DETERMINED BY THE "INPUT MODE" IN THE "SETUP" GROUP. THE NUMBER FOR INPUT MODE CHANGES THE CONFIGURATION OF THE TERMINAL. THIS IS IMPORTANT TO KNOW TO DETERMINE WHETHER IT IS TWO WIRE OR THREE WIRE CONTROL AND ALL OTHER OPTIONS LIKE SPEED SELECT WHICH WE DISCUSS LATER.
- 4) IT IS IMPORTANT TO NOTE THE 1336 DRIVE NEEDS TERMINAL 19(STOP), TERMINAL 24(AUXILIARY), AND TERMINAL 30(ENABLE) ENERGIZED(TRUE) TO START THE DRIVE. THIS IS NOT NECESSARY IN THE PF750 IF YOU DON'T USE THEM IF ARE JUMPERED OUT ON TERMINAL BLOCK.
- 5) BULLETIN NUMBERS DETERMINE A 1336PLUS(1336S) FROM A 1336PLUSII(1336F) THIS EFFECTS THE CONFIGURATION OF TB2 IF THE 1336PLUSII HAS 1336-LA CARDS. THE 1336PLUSII DRIVE HAS A "SNAP IN" HIM, THE 1336PLUS HAS A 8 PIN MINI DIN ROUND CONNECTOR, THIS IS ANOTHER WAY TO DETERMINE WHICH FLAVOR YOU ACTUALLY HAVE. ON LARGER FRAMES THE 1336-LA CARDS WILL BE MOUNTED ON MAIN CONTROL BOARD(3"X2" CIRCUIT BOARD).
- 6) THE 1336-LA CARDS NEEDED TO BE SCALED AT 4-20 mA WITH STRANGE ANALOG LO AND ANALOG HI VALUES. THE PF750 ANALOG OUTPUTS ARE DEAD ON AND DO NOT REQUIRE SPECIAL SCALING

1336PLUS THREE WIRE EXAMPLE:

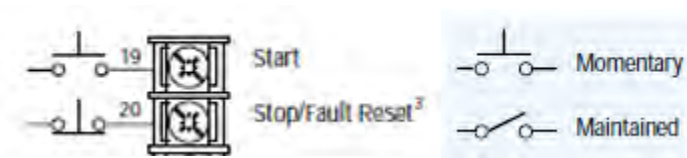

3 WIRE NOMENCLATURE
 “START” & “STOP”
 ALL MOMENTARY PB.

1336PLUS TWO WIRE EXAMPLE:



2 WIRE NOMENCLATURE
 “RUN”
 MAINTAINED SWITCH

SO THE 1336PLUS SET TWO OR THREE WIRE CONTROL FROM “INPUT MODE” PARAMETER

YOU WILL HAVE TO PROGRAM THE UNASSIGNED INPUTS IN THE PF750 TO EITHER 2 OR 3 WIRE CONTROL.

PF750 PARAMETERS THREE WIRE CONTROL:

Feedback & I/O	Digin Functions	Digital In Cfg	150	DI Start 161	DI Jog 1 Reverse	168	DI Speed Sel 2	175	
		DI Enable	155	DI Fwd Reverse	162	DI Jog 2	169	DI HOA Start	176
		DI Clear Fault	156	DI Run	163	DI Jog 2 Forward	170	DI Accel 2	179
		DI Aux Fault	157	DI Run Forward	164	DI Jog 2 Reverse	171	DI Decel 2	180
		DI Stop 158	158	DI Run Reverse	165	DI Manual Ctrl	172		
		DI Cur Lmt Stop	159	DI Jog 1	166	DI Speed Sel 0	173		
		DI Coast Stop	160	DI Jog 1 Forward	167	DI Speed Sel 1	174		

PF750 PARAMETERS TWO WIRE CONTROL:

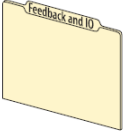
Feedback & I/O	Digin Functions	Digital In Cfg	150	DI Start	161	DI Jog 1 Reverse	168	DI Speed Sel 2	175
		DI Enable	155	DI Fwd Reverse	162	DI Jog 2	169	DI HOA Start	176
		DI Clear Fault	156	DI Run 163	163	DI Jog 2 Forward	170	DI Accel 2	179
		DI Aux Fault	157	DI Run Forward 164	164	DI Jog 2 Reverse	171	DI Decel 2	180
		DI Stop	158	DI Run Reverse 165	165	DI Manual Ctrl	172		
		DI Cur Lmt Stop	159	DI Jog 1	166	DI Speed Sel 0	173		
		DI Coast Stop	160	DI Jog 1 Forward	167	DI Speed Sel 1	174		

THE POWERFLEX 750 HAS PORTS THAT YOU CAN PUT INPUT/OUTPUT MODULES(CARDS) IN THE SLOTS. THE PF753 HAS THREE PORTS TO PLACE I/O INTO BESIDES THE EMBEDDED I/O ON THE MAIN CONTROL BOARD. THE PF755 HAS 5 PORTS THAT CAN BE USED FOR I/O, FEEDBACK, RESOLVER CARDS, ETC.

TYPICAL PORTS ON THE PF750 ARE PORT 4,5,6 TO PLACE 120VAC OR 24VDC CARDS IN THE SLOTS LEFT OF THE MAIN CONTROL BOARD(4,5,6).

TO ACCESS THESE PORTS –

Press the 'Folders' button  on the HIM keypad. The button is located on the bottom row of the HIM Keypad (shown circled in the left image below). Pressing the 'Folders' button changes the HIM screen display to the Folders screen (see right image below)



ASSIGN THE I/O FUNCTION SUCH AS “RUN”(PARAMETER 163 IN PORT “0”) TO THE INPUT IN THE PORT AND TERMINAL POINT WHERE YOUR I/O CARD IS LOCATED. PORT “0” IS THE MAIN CONTROL BOARD IF YOU ARE USING I/O IN THIS LOCATION.

SPEED SELECT USING INPUTS 1336PLUS

Speed Select/Frequency Reference

The drive speed command can be obtained from a number of different sources. The source is determined by drive programming and the condition of the Speed Select Inputs on TB3 (or reference select bits of command word if PLC controlled – see Appendix A).

The default source for a command reference (all speed select inputs open) is the selection programmed in [Freq Select 1]. If any of the speed select inputs are closed, the drive will use other parameters as the speed command source. Refer to Table 2.H and the examples that follow.

Table 2.H
Speed Select Input State vs. Frequency Source

Speed Select 3	Speed Select 2	Speed Select 1	Frequency Source
Open	Open	Open	[Freq Select 1]
Open	Open	Closed	[Freq Select 2]
Accessed through [Freq Select 2] parameter			[Preset Freq 1]
Open	Closed	Open	[Preset Freq 2]
Open	Closed	Closed	[Preset Freq 3]
Closed	Open	Open	[Preset Freq 4]
Closed	Open	Closed	[Preset Freq 5]
Closed	Closed	Open	[Preset Freq 6]
Closed	Closed	Closed	[Preset Freq 7]

Important: The final speed command may be affected by the type of modulation selected with [Speed Control], parameter 77. Refer to [Speed Control] in Chapter 5 for further information.

Example 1

Input Mode 2 – Application calls for a local Human Interface Module (HIM) speed command or remote 4-20mA from a PLC. The drive is programmed as follows:

- [Freq Select 1] = Adapter 1
- [Freq Select 2] = 4-20mA

With Speed Select inputs 2 & 3 open and the selector switch set to “Remote” (Speed Select 1 closed), the drive will follow [Freq Select 2] or 4-20mA. With the switch set to “Local” (Speed Select 1 open) all speed select inputs are open and the drive will follow the local HIM (Adapter 1) as selected with [Freq Select 1].

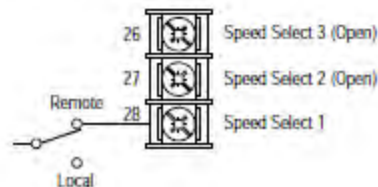

Example 2

Input Mode 7 – Application is to follow a local HIM unless a preset speed is selected. The drive is programmed as follows:

- [Freq Select 1] = Adapter 1
- [Freq Select 2] = Preset Freq 1
- [Preset Freq 1] = 10 Hz.
- [Preset Freq 2] = 20 Hz.
- [Preset Freq 3] = 30 Hz.

Contact operation for the speed select switch is described in the table below. Since Input Mode 7 does not offer a Speed Select 3 input, [Preset Freq 4-7] are not available.

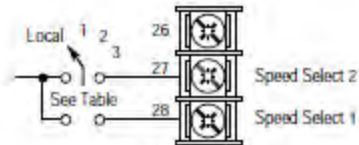

Switch Position	Speed Select Input		Parameter Used for Speed Ref.	Programmed Setting
	1 (#28)	2 (#27)		
Local	Open	Open	[Freq Select 1]	Adapter 1
1	Closed	Open	[Freq Select 2]	Preset Freq 1
2	Open	Closed	[Preset Freq 2]	20 Hz.
3	Closed	Closed	[Preset Freq 3]	30 Hz.

ASSIGN THE PF750 SPEED SELECTS TO I/O(PARAMETERS 173,174,175):

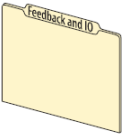
Feedback & I/O	Digin Functions	Digital In Cfg	150	DI Start	161	DI Jog 1 Reverse	168	DI Speed Sel 2	175
		DI Enable	155	DI Fwd Reverse	162	DI Jog 2	169	DI HOA Start	176
		DI Clear Fault	156	DI Run	163	DI Jog 2 Forward	170	DI Accel 2	179
		DI Aux Fault	157	DI Run Forward	164	DI Jog 2 Reverse	171	DI Decel 2	180
		DI Stop	158	DI Run Reverse	165	DI Manual Ctrl	172		
		DI Cur Lmt Stop	159	DI Jog 1	166	DI Speed Sel 0	173		
		DI Coast Stop	160	DI Jog 1 Forward	167	DI Speed Sel 1	174		

ASSIGNING ANALOG I/O

1336PLUS TERMINAL BLOCK EXAMPLE 4-20 mA:

THIS IS A 1336PLUSII EXAMPLE WITH 1336-LA CARDS USED IN PLUSII
REMOVE WIRES FROM TERMINALS 4(-) & 6(+).

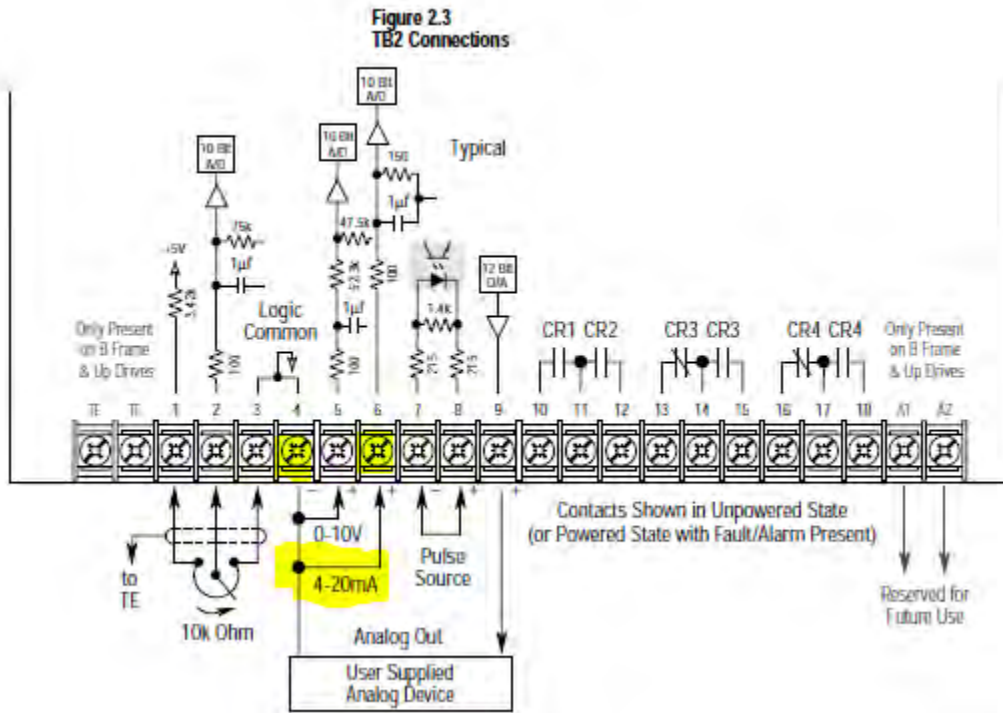

1336PLUSII TERMINAL BLOCK EXAMPLE 4-20 mA INPUT:

THIS IS A 1336PLUSII EXAMPLE WITH 1336-LA CARDS USED IN PLUSII
 REMOVE WIRES FROM TERMINALS TO PLACE ON PF750.

Analog I/O

The 1336 PLUS II analog I/O configuration provides a standard set of inputs and outputs with the capability to install up to 2 option boards, thus replacing the standard I/O with a variety of options. All connections are performed at TB2. Installing an option board in the slot A or B location will change the function of those terminals on TB2 from standard. Only one option board can be installed in each slot. [Figure 2.6](#) shows the standard and optional I/O configurations.

Figure 2.6
Analog I/O – TB2

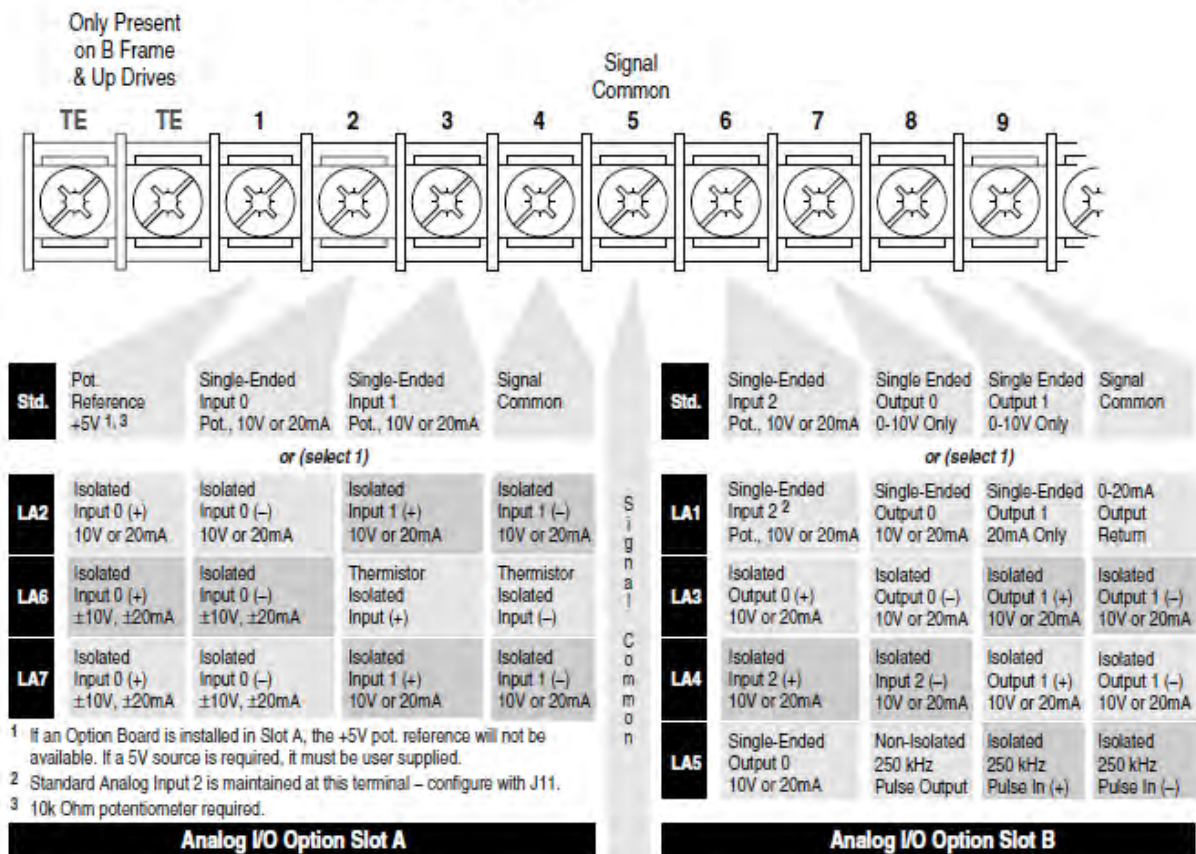

REMOVE THE CHANNEL WIRES FROM THE APPROPRIATE 1336-LA CARD THAT IS INSERTED IN EITHER OPTION SLOT A OR OPTION SLOT B.

THE EXAMPLE WE WILL USE WILL BE A 20-750-2262D-2R I/O CARD IN SLOT 4 IN THE PF753 DRIVE. USE THE FOLDERS BUTTON ON HIM AND GO TO PORT 4. YOU WILL NOTICE PORT 4 HAS PARAMETERS IN THE CARD. GO TO PARAMETER 45 IN THE 2262 MODULE:

45 Anlg In Type

Analog Input Type

Status of the analog input mode set by the option jumpers.

Options	Reserved	Reserved	Reserved	Reserved	Reserved	Reserved	Reserved	Reserved	Reserved	Reserved	Reserved	Reserved	Reserved	Reserved	Reserved	Analog 1	Analog 0
Default	0	0	0	0	0	0	0	0	0	0	0	0	0	0	0	0	0
Bit	15	14	13	12	11	10	9	8	7	6	5	4	3	2	1	0	

0 = Voltage Mode
1 = Current Mode

CHANGE ANALOG 0 TYPE TO “1” FOR 4-20mA.

MOVE JUMPER SHOWN IN TABLE BELOW, WIRE TO Ai0.

22-Series I/O Module TB1 Wiring Examples (Continued)

Input/Output	Connection Example	Required Parameter Changes
Analog Current Input Unipolar Speed Reference 0-20 mA Input	<p>22-Series I/O Module TB1</p>	<ul style="list-style-type: none"> Set Direction Mode Port 0: P308 [Direction Mode] = 0 “Unipolar” Set Selection Port 0: P545 [Spd Ref A Sel] = Port X (22-Series I/O Module): P50 [Anlg In0 Value] Adjust Scaling Port X (22-Series I/O Module): P51 [Anlg In0 Hi] = 20 mA Port X (22-Series I/O Module): P52 [Anlg In0 Lo] = 0 mA Port 0: P547 [Spd Ref A AnlgHi] = 60 Hz Port 0: P548 [Spd Ref A AnlgLo] = 0 Hz View Results Port X (22-Series I/O Module): P50 [Anlg In0 Value] Port 0: P592 [Selected Spd Ref]

CHECK SCALING(P52 SHOULD BE AT “4” FOR SIGNAL LOSS)

WE WILL SET THE ANALOG INPUT FOR THE DRIVE SPEED REFERENCE IN THIS EXAMPLE:

USE THE FOLDERS BUTTON NAVIGATE BACK TO PORT 0
 ACCESS THE PARAMETER 545 IN PORT 0 – SPEED REFERENCE

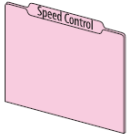
	Speed Control	Speed Limits	Max Fwd Speed	520	Max Rev Speed	521	Min Fwd Speed	522	Min Rev Speed	523	
	Speed Ramp Rates	Accel Time 1	535	Decel Time 1	537	Jog Acc Dec Time	539				
		Accel Time 2	536	Decel Time 2	538						
	Speed Reference	Spd Ref A Sel	545	Spd Ref B Stpt	551	MOP Init Select	566	Preset Speed 4	574		
		Spd Ref A Stpt	546	Spd Ref B AnlgHi	552	MOP Init Stpt	567	Preset Speed 5	575		
		Spd Ref A AnlgHi	547	Spd Ref B AnlgLo	553	Preset Speed 1	571	Preset Speed 6	576		
		Spd Ref A AnlgLo	548	Jog Speed 1	556	Preset Speed 2	572	Preset Speed 7	577		
		Spd Ref B Sel	550	Jog Speed 2	557	Preset Speed 3	573				

POINT PARAMETER 545 TO PORT 4 Ai0.
 SPEED REFERENCE IS NOW SET.

SETTING AN ANALOG OUTPUT

1336PLUS DRIVE ANALOG OUT

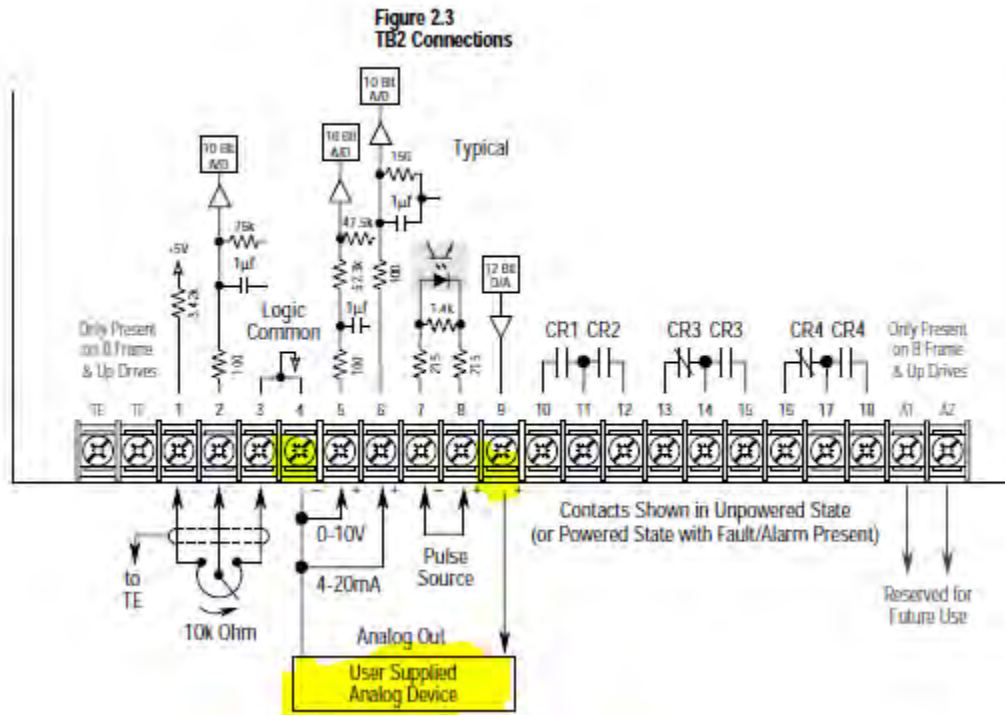

REMOVE WIRES FROM TERMINAL 4(-) AND TERMINAL (+) FROM 1336PLUS, PLEASE KEEP IN MIND THE 1336PLUSII HAS A DIFFERENT ARRANGEMENT PLEASE REFER TO 1336PLUSII CONFIGURATION FOR DETAILS.

1336PLUSII DRIVE ANALOG OUT

Analog I/O

The 1336 PLUS II analog I/O configuration provides a standard set of inputs and outputs with the capability to install up to 2 option boards, thus replacing the standard I/O with a variety of options. All connections are performed at TB2. Installing an option board in the slot A or B location will change the function of those terminals on TB2 from standard. Only one option board can be installed in each slot. [Figure 2.6](#) shows the standard and optional I/O configurations.

Figure 2.6
Analog I/O – TB2

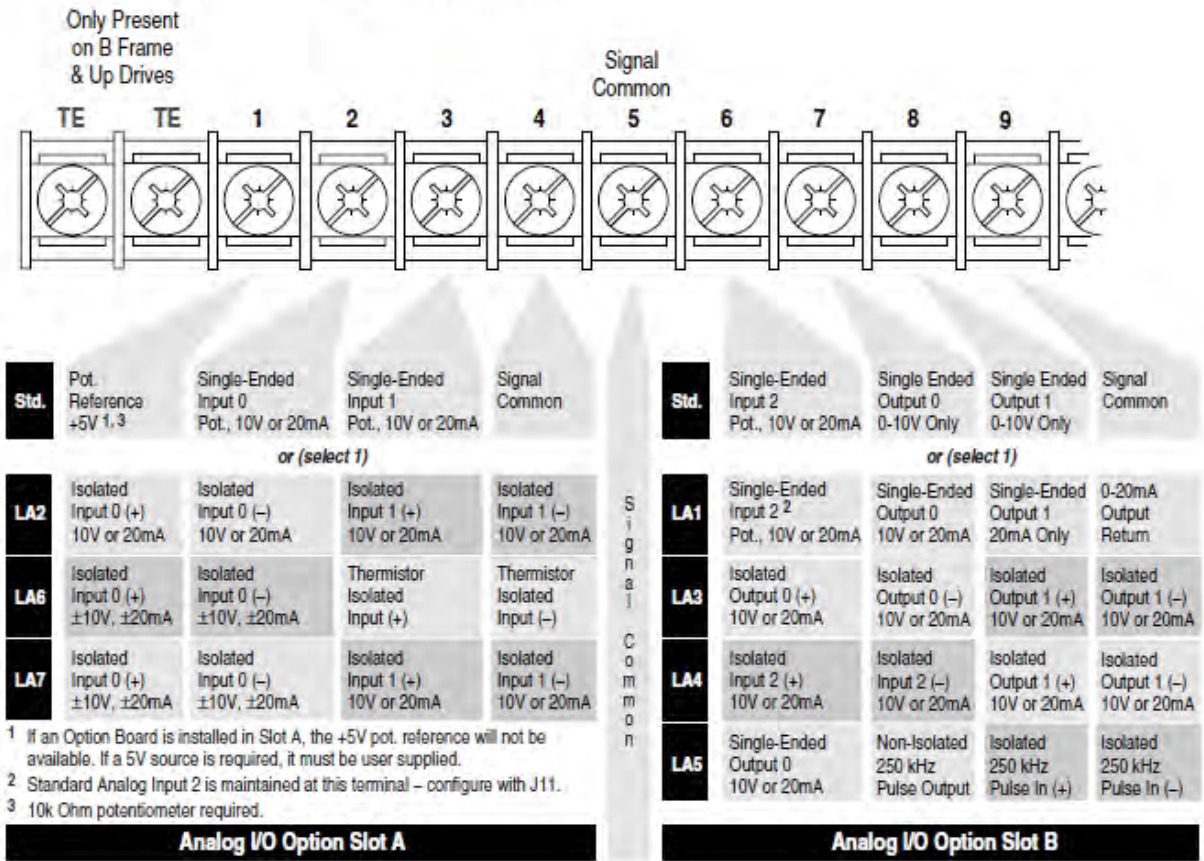

REMOVE WIRES FROM ANALOG OUT ON 1336-LA CARD LOCATED IN SLOT B. PLEASE KEEP TRACK OF POLARITY TO LAND PROPERLY ON PF753. ALL ANALOG OUTPUTS ON PF753 ARE ISOLATED FOR NOISE IMMUNITY. THERE IS NO PROBLEM CONVERTING A SINGLE ENDED NON ISOLATED OUTPUT FROM A 1336PLUS OR 1336PLUSII AND PLACING IT ON A PF750 ANALOG OUTPUT.

ANALOG SETUP
THIS EXAMPLE IS FOR PORT 4 Ai0 CONNECTON
22-Series I/O Module

20-750-2262C-2R (24 Volts DC)
 20-750-2263C-1R2T (24 Volts DC)
 20-750-2262D-2R (120 Volts AC)

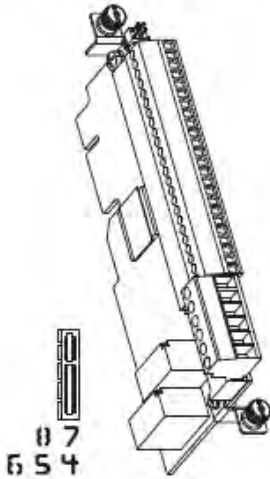

Table 59 - Input Mode Jumpers

Jumper Position	Voltage Mode	Current Mode

Table 60 - TB1 Terminal Designations

Terminal	Name	Description	Related Param ⁽⁵⁾
Sh	Shield	Terminating point for wire shields when an EMC plate or conduit box is not installed.	
Ptc-	Motor PTC (-)	Motor protection device (Positive Temperature Coefficient). ⁽²⁾	40 on Port X
Ptc+	Motor PTC (+)		
Ao0-	Analog Out 0 (-)	Bipolar, ±10V, 11 bit & sign, 2 k ohm minimum load. 4-20 mA, 11 bit & sign, 400 ohm maximum load.	75 on Port X
Ao0+	Analog Out 0 (+)		
Ao1-	Analog Out 1 (-)		85 on Port X
Ao1+	Analog Out 1 (+)		
-10V	-10 Volt Reference	2k ohm minimum.	
10VC	10 Volt Common	For (-) and (+) 10 Volt references.	
+10V	+10 Volt Reference	2k ohm minimum.	
Ai0-	Analog Input 0 (-)	Isolated ⁽³⁾ , bipolar, differential, 11 bit & sign. Voltage Mode: ±10V @ 88k ohm input impedance. Current Mode: 0-20 mA @ 93 ohm input impedance.	50, 70 on Port X
Ai0+	Analog Input 0 (+)		
Ai1-	Analog Input 1 (-)		60, 70 on Port X
Ai1+	Analog Input 1 (+)		
24VC	24 Volt Common	Drive supplied logic input power. 200 mA max. per I/O module 600 mA max per drive	
+24V	+24 Volt DC		
Di C	Digital Input Common	Common for Digital Inputs 0...5	
Di 0	Digital Input 0 ⁽¹⁾	24V DC (30V DC Max.) - Opto isolated	1 on Port X
Di 1	Digital Input 1 ⁽¹⁾	High State: 20...24V DC 11.2 mA DC	
Di 2	Digital Input 2 ⁽¹⁾	Low State: 0...5V DC	
Di 3	Digital Input 3 ⁽¹⁾	120V AC (132V AC Max.) 50/60 Hz ⁽⁴⁾ - Opto isolated	
Di 4	Digital Input 4 ⁽¹⁾	High State: 100...132V AC	
Di 5	Digital Input 5 ⁽¹⁾	Low State: 0...30V AC	

WIRE THE ANALOG CONNECTIONS FROM THE TERMINAL 4(-) ON 1336PLUS TO THE Ai0- TERMINAL ON 20-750-2262 I/O CARD IN SLOT 4 OF POWERFLEX DRIVE. KEEP IN MIND WHATEVER PORT YOU PUT THE CARD IN IS THE PORT YOU SEEK TO TIE THE ANALOG POINT TO THE DRIVE FUNCTION. IN THIS EXAMPLE IT IS OUTPUT CURRENT VALUE FROM THE DRIVE IN PORT 0(MCB).

ON THE PF750 DRIVE GO TO PORT 4 USING THE FOLDERS BUTTON
 IN PORT 4 PARAMETERS GO TO PARAMETER 70. CHANGE THIS VALUE TO A “1”
 FOR 4-20 mA.

70	Anlg Out Type																
	Analog Output Type																
	Select the analog output mode for each analog output.																
	Options	Reserved	Reserved	Reserved	Reserved	Reserved	Reserved	Reserved	Reserved	Reserved	Reserved	Reserved	Reserved	Reserved	Reserved	Reserved	Reserved
Default	0	0	0	0	0	0	0	0	0	0	0	0	0	0	0	0	0
Bit	15	14	13	12	11	10	9	8	7	6	5	4	3	2	1	0	

0 = Voltage Mode
 1 = Current Mode

FOR THIS EXAMPLE WE WILL USE THE CURRENT VALUE FOR THE ANALOG
 OUTPUT FROM THE DRIVE.

75	Anlg Out0 Sel Analog Output 0 Select Selects the source for the analog output.	Default: 3 Min/Max: 0 / 159999	RW	32-bit Integer
76	Anlg Out0 Stpt Analog Output 0 Setpoint A possible source for an analog output. Can be used to control an analog output from a communication device using a DataLink. Not affected by analog output scaling.	Units: Volt mA Default: 10.000 Volts 20.000 mA Min/Max: -/+10.000 Volts 0.000 / 20.000 mA	RW	Real
77	Anlg Out0 Data Analog Output 0 Data Displays the value of the source selected by P75 [Anlg Out0 Sel].	Default: 0 Min/Max: -/+40000.000	RO	Real
78	Anlg Out0 DataHi Analog Output 0 Data High Sets the high value for the data range of analog out scale.	Units: pu Default: 1 Min/Max: -/+40000.000	RW	Real
79	Anlg Out0 DataLo Analog Output 0 Data Low Sets the low value for the data range of analog out scale.	Default: 1 Min/Max: -/+40000.000	RW	Real
80	Anlg Out0 Hi Analog Output 0 High Sets the high value for the analog output value when the data value is at its maximum.	Units: Volt mA Default: 10.000 Volts 20.000 mA Min/Max: -/+10.000 Volts 0.000 / 20.000 mA	RW	Real
81	Anlg Out0 Lo Analog Output 0 Low Sets the low value for the analog output value when the data value is at its minimum.	Units: Volt mA Default: 0.000 Volts 0.000 mA Min/Max: -/+10.000 Volts 0.000 / 20.000 mA	RW	Real

SET PARAMETER 75 FOR OUTPUT CURRENT OF DRIVE. ANALOG OUT0 LOW SHOULD BE “4” AND ANALOG OUT0 HIGH SHOULD BE “20”.

YOU CAN OBSERVE THE VALUE ON THE CHANNEL AFTER YOU WIRE IT BY LOOKING IN PORT 4. LOOK AT PARAMETER 82.

82	Anlg Out0 Val Analog Output 0 Value Displays the analog output value.	Units:	Volt	RO	Real
			mA		
		Default:	10.000 Volts 20.000 mA		
		Min/Max:	-/+10.000 Volts 0.000 / 20.000 mA		

THE CURRENT VALUE IN DRIVE COULD BE 0-200% SO CHECK YOUR SCALING!

ENCODER OPTION ON TB3 I/O BOARD 1336

1336LxE card

x=voltage rating of I/O card

Figure 2.6 d
Encoder Signal Wiring

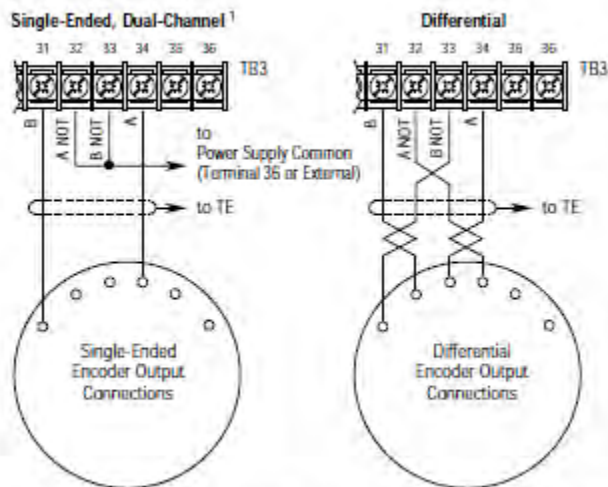

¹ For Single-Ended, Single-Channel (pulse) applications, eliminate the B and B (NOT) connections. Some encoders may label the "A" connection as "Signal."

REMOVE ENCODER WIRES IN PAIRS FROM THE 1336-LxE CARD, WHEN IT IS A DIFFERENTIAL(QUADRATURE ENCODER). THIS WILL LOWER THE NUMBER OF COMBINATIONS WHEN LANDING ENCODER WIRES ON PF750. IF THE PF750 GIVES A HARDWARE OVERCURRENT FAULT SWAP LEADS A AND A- OR B AND B- LEADS TO GET PROPER POLARITY WITH EACH PAIR.

22-Series I/O Module

20-750-2262C-2R (24 Volts DC)
 20-750-2263C-1R2T (24 Volts DC)
 20-750-2262D-2R (120 Volts AC)

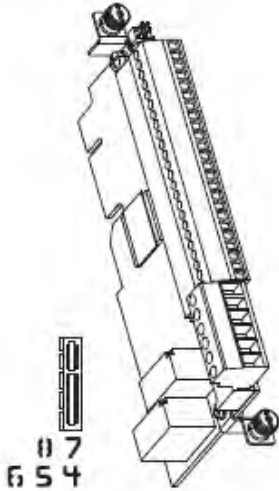

Table 59 - Input Mode Jumpers

Jumper Position	Voltage Mode	Current Mode
		

Table 60 - TB1 Terminal Designations

Terminal	Name	Description	Related Param ⁽⁵⁾
Sh	Shield	Terminating point for wire shields when an EMC plate or conduit box is not installed.	
Ptc-	Motor PTC (-)	Motor protection device (Positive Temperature Coefficient). ⁽²⁾	40 on Port X
Ptc+	Motor PTC (+)		
Ao0-	Analog Out 0 (-)	Bipolar, $\pm 10V$, 11 bit & sign, 2 k ohm minimum load. 4-20 mA, 11 bit & sign, 400 ohm maximum load.	75 on Port X
Ao0+	Analog Out 0 (+)		
Ao1-	Analog Out 1 (-)		85 on Port X
Ao1+	Analog Out 1 (+)		
-10V	-10 Volt Reference	2k ohm minimum.	
10VC	10 Volt Common	For (-) and (+) 10 Volt references.	
+10V	+10 Volt Reference	2k ohm minimum.	
Ai0-	Analog Input 0 (-)	Isolated ⁽³⁾ , bipolar, differential, 11 bit & sign. Voltage Mode: $\pm 10V$ @ 88k ohm input impedance. Current Mode: 0-20 mA @ 93 ohm input impedance.	50, 70 on Port X
Ai0+	Analog Input 0 (+)		
Ai1-	Analog Input 1 (-)		60, 70 on Port X
Ai1+	Analog Input 1 (+)		
24VC	24 Volt Common	Drive supplied logic input power. 200 mA max. per I/O module 600 mA max per drive	
+24V	+24 Volt DC		
Di C	Digital Input Common	Common for Digital Inputs 0...5	
Di 0	Digital Input 0 ⁽¹⁾	24V DC (30V DC Max.) - Opto isolated High State: 20...24V DC 11.2 mA DC Low State: 0...5V DC 120V AC (132V AC Max.) 50/60 Hz ⁽⁴⁾ - Opto isolated High State: 100...132V AC Low State: 0...30V AC	1 on Port X
Di 1	Digital Input 1 ⁽¹⁾		
Di 2	Digital Input 2 ⁽¹⁾		
Di 3	Digital Input 3 ⁽¹⁾		
Di 4	Digital Input 4 ⁽¹⁾		
Di 5	Digital Input 5 ⁽¹⁾		

(1) Digital Inputs are either 24 Volts DC (2262C) or 115 Volts AC (2262D) based on module catalog number. Ensure applied voltage is correct for I/O module.

(2) See HW Input PTC on page 258 for PTC data.

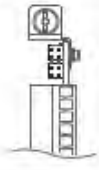
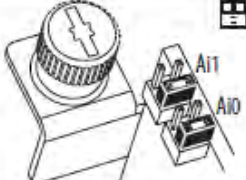
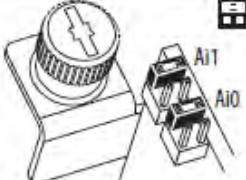
(3) Differential Isolation - External source must be maintained at less than 160V with respect to PE. Input provides high common mode immunity.

(4) For CE compliance use shielded cable. Cable length should not exceed 30 m (98 ft).

(5) I/O Module parameters will also have a Port designation.



ATTENTION: Risk of equipment damage exists. Ensure that the correct voltage is applied to the I/O Module digital inputs. Refer to the I/O Module catalog number to determine the voltage rating.

- 20-750-2262C-2R is rated 24 Volts DC
- 20-750-2263C-1R2T is rated 24 Volts DC
- 20-750-2262D-2R is rated 120 Volts AC

Table 61 - TB2 Terminal Designations (2 Relay Outputs: 2R)

Relay Out	Terminal	Name	Description	Related Param
	R0NO	Relay 0 N.O.	Relay Normally Open contact output:	10, 100,
	R0C	Relay 0 Common	240V AC, 24V DC, 2 A max.	101, 105,
	R0NC	Relay 0 N.C.	General Purpose (Inductive) / Resistive	106
	R1NO	Relay 1 N.O.	Relay Normally Closed contact output:	on Port X
	R1C	Relay 1 Common	240V AC, 24V DC, 2 A max.	20, 110,
	R1NC	Relay 1 N.C.	Resistive Only	111, 115, 116

20-750-2262C IS 24VDC INPUTS WITH (X2) ELECTROMECHANICAL RELAYS

20-750-2262D IS 120VAC INPUTS WITH (X2) ELECTROMECHANICAL RELAYS

20-750-2263C-1R2T IS 24VDC INPUTS WITH (X1) EM RELAY AND (X2) TRANSISTORS

PLEASE KEEP IN MIND THE FAULT FUNCTION HAS A STATE CONDITION FOOTNOTE AND DISPLAYS THE ENERGIZED STATE FOR THE FAULT CONDITION IN THE DIAGRAM.

TYPICAL PARAMETERS TO CHECK

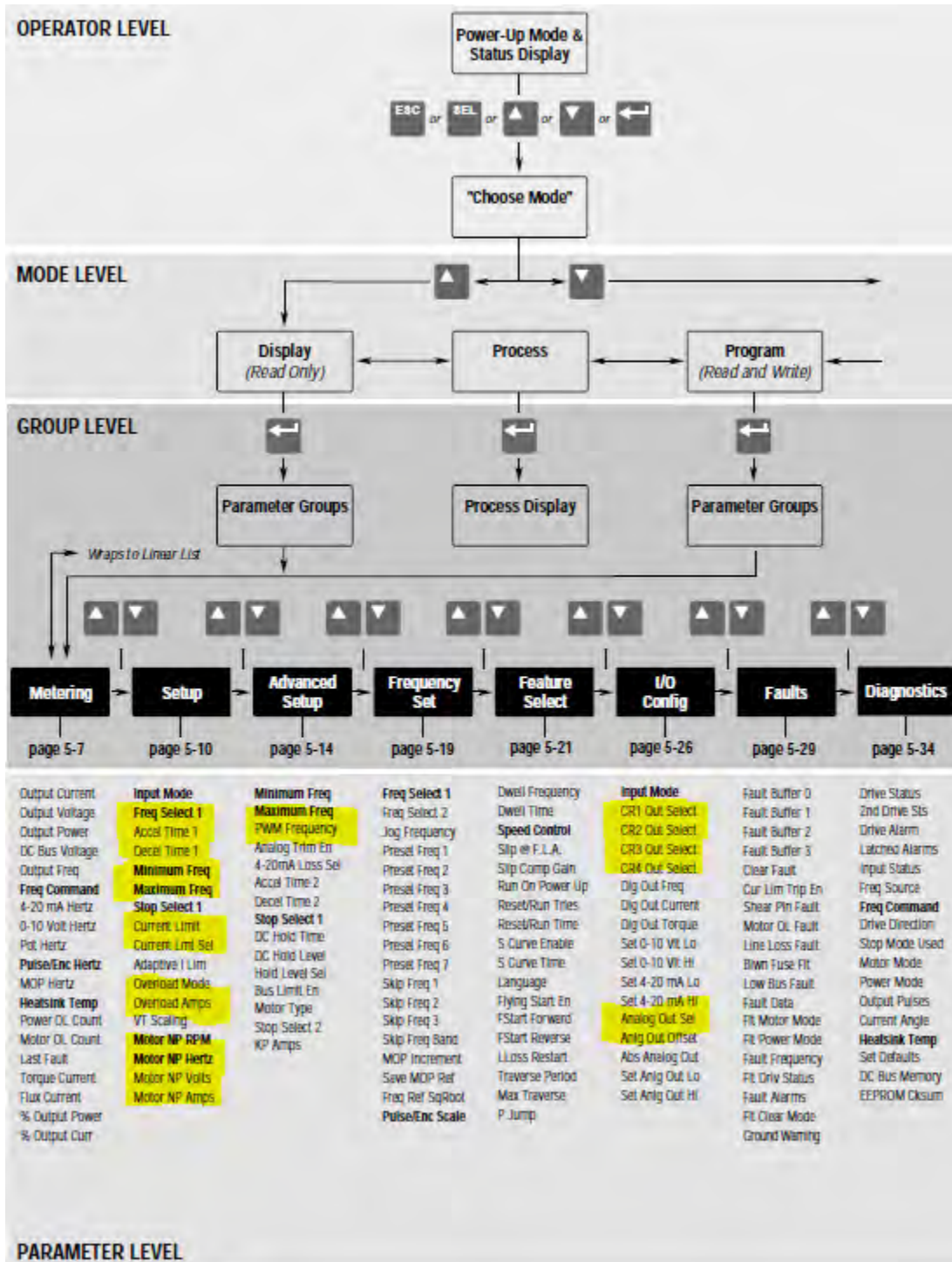

THE HIGHLIGHTED PARAMETERS ARE MINIMAL PARAMETERS TO CHECK WITH DRIVE TOOLS SOFTWARE OR KEYPAD. ABOVE IS THE MAP AND KEYSTROKES TO ACHIEVE THIS INFORMATION. AT THE BARE MINIMUM WRITE IT DOWN TO CORRELATE TO THE PF750 PARAMETERS.

Correlate the 1336Plus Parameters to the PF750

LET'S LOOK AT THE WHAT WE BASICALLY NEED TO MAKE AN AC DRIVE WORK:

- 1) A WAY TO START AND STOP THE DRIVE
- 2) A SPEED REFERENCE TO TELL IT HOW FAST IT OPERATES
- 3) MOTOR DATA TO PROTECT THE MOTOR AND INCREASE PERFORMANCE

THESE ARE THE MINIMUM REQUIREMENTS TO GET A DRIVE TO OPERATE.

HOW DO WE DETERMINE THE CONTROL METHOD IN WHICH THE DRIVE STARTS AND STOPS? THERE ARE TWO METHODS:

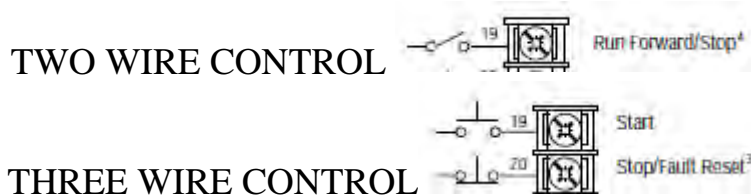

“**RUN**” IS THE TERM FOR TWO WIRE CONTROL PLEASE OBSERVE THE TYPE OF SWITCH THAT IS USED ALSO – A MAINTAINED SWITCH. WHEN THE SWITCH IS CLOSED THE DRIVE IS ACTIVE, WHEN THE SWITCH IS OPEN IT STOPS.

“**START**” AND “**STOP**” ARE THE TERMS FOR THREE WIRE CONTROL, ABOVE SHOWS THE MOMENTARY STYLE SWITCH USED IN THIS METHOD.

WHAT WILL TELL US WHICH CONTROL METHOD THE 1336PLUS USES? THIS WILL BE THE **INPUT MODE** ON THE 1336PUS DRIVE.

HERE IS THE STATUS SCREEN ON DRIVE:



IF THIS SCREEN DOES NOT SHOW HIT THE “**ESC**” ON KEYPAD TILL THIS SCREEN APPEARS.

HIT THE “**ENTER**” KEY ON THE HIM(KEYPAD) THE SCREEN SHOULD LOOK LIKE THIS:



THE MODE SHOULD BE IN **PROGRAM** MODE, IF NOT USE THE UP AND DOWN KEYS TO MAKE THE SECOND LINE “PROGRAM”. HIT THE **ENTER** KEY.

GO TO THE **GROUP** CALLED **SETUP** USING THE UP AND DOWN ARROW KEYS THE SCREEN SHOULD LOOK LIKE THIS:

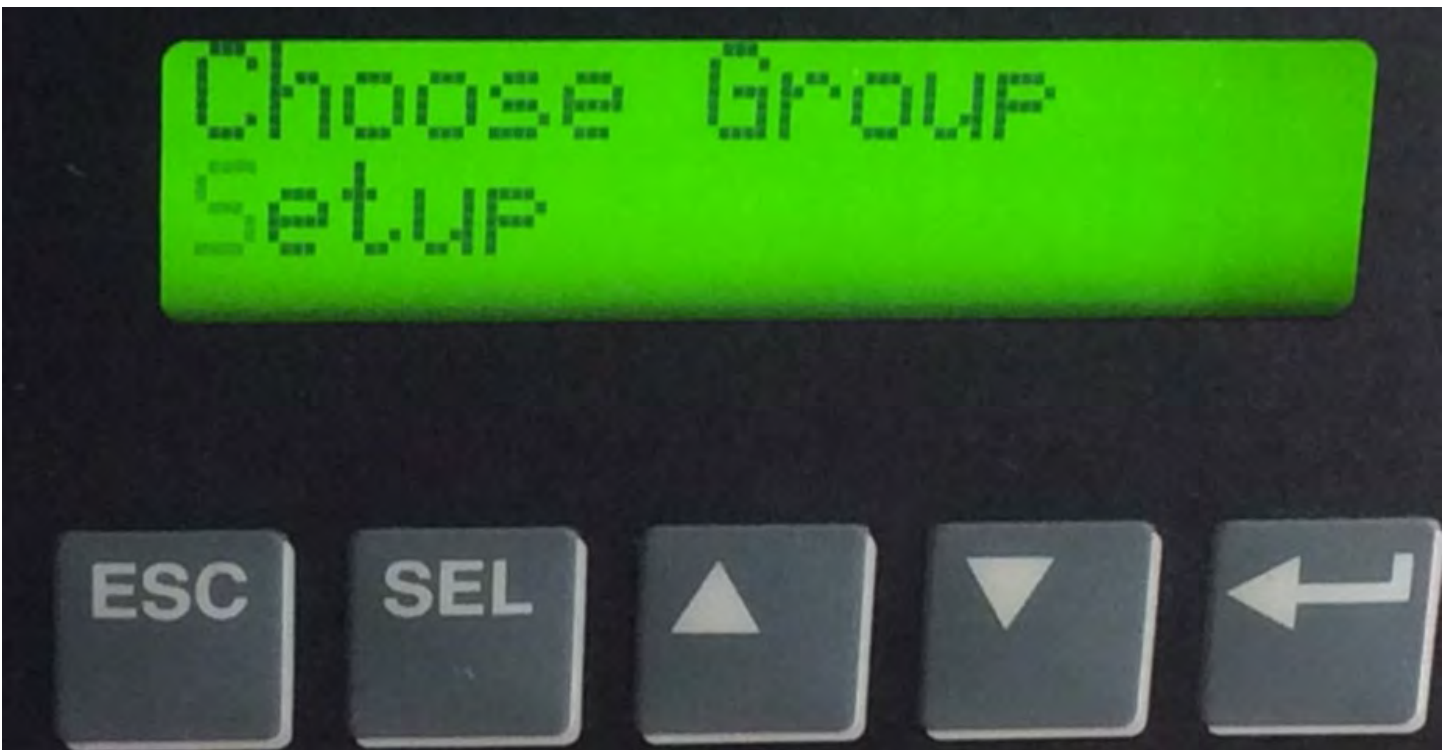
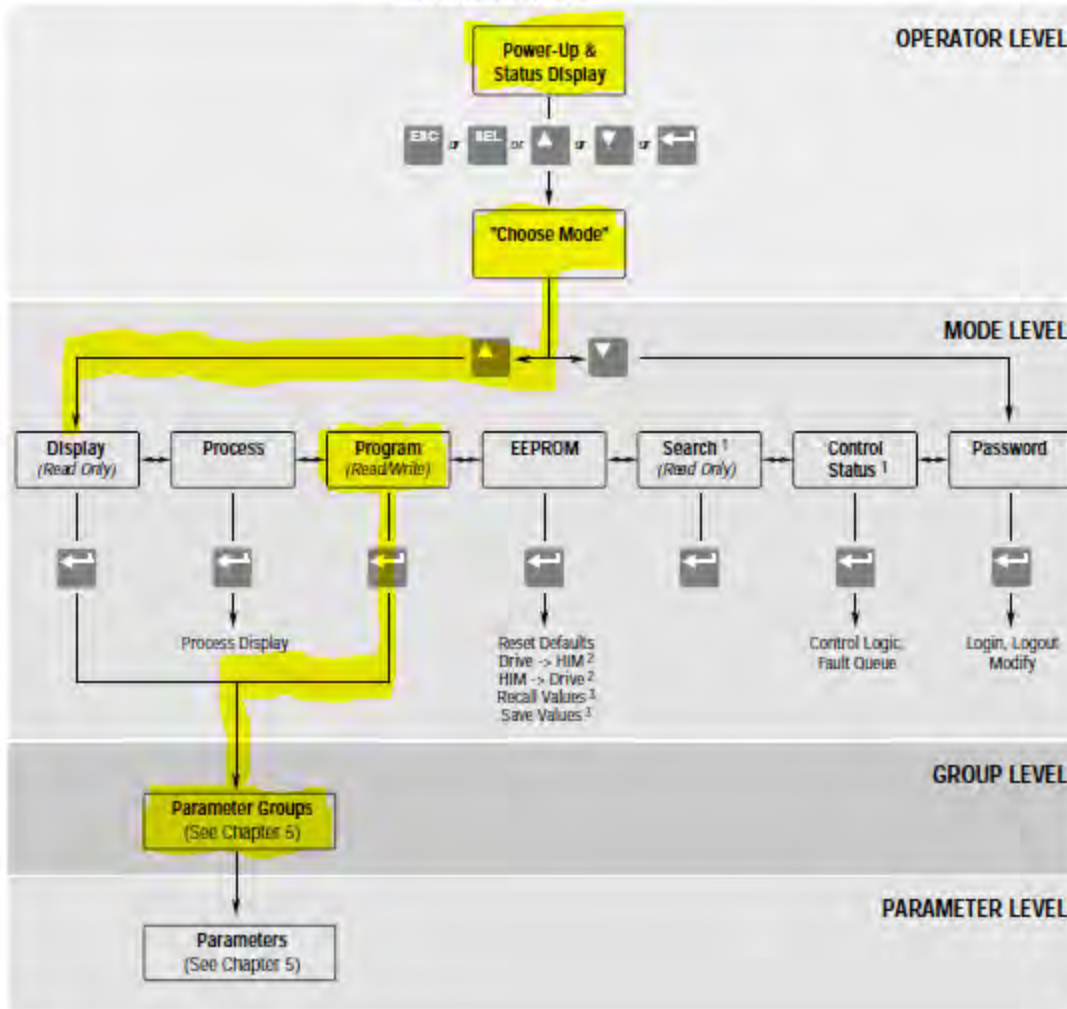

FIGURE 3.5 BELOW SHOWS THE PATH WE TOOK TO GET TO THE **SETUP GROUP**.

THE **SETUP GROUP** HAS A MAJORITY OF THE PARAMETERS WE NEED TO EXTRACT OUT OF THE 1336PLUS DRIVE TO KNOW HOW TO PROGRAM THE PF753 DRIVE.

Figure 3.5
HIM Programming Steps



¹ Series A (Version 3.0) and Series B HIM Only.

² Series B HIM Only.

³ Reserved for Future Use.



WE NEED TO KNOW IF WE ARE TWO OR THREE WIRE CONTROL WE WILL FIND THIS OUT FROM THE PARAMETER "INPUT MODE".

NAVIGATE USING THE UP AND DOWN KEYS ON KEYPAD TO SCROLL THROUGH THE SETUP GROUP AND FIND **INPUT MODE**. THE SCREEN SHOULD LOOK LIKE THIS:



THIS DRIVE IS CONFIGURED FOR 3 WIRE CONTROL, SO IN THE FIELD YOU HAVE A MOMENTARY PUSHBUTTON FOR START AND SOME FORM OF STOP. PLEASE NOTE THIS IS A **1336PLUSII** SHOWING 3 WIRE CONFIGURATION. THE 1336PLUS USES A NUMERIC DESIGNATION FOR THE INPUT MODE. LET'S LOOK AT INPUT MODE FOR A 1336PLUS.

Figure 2.5
Input Mode Selection & Typical TB3 Connections

[Input Mode] 1
Factory Default

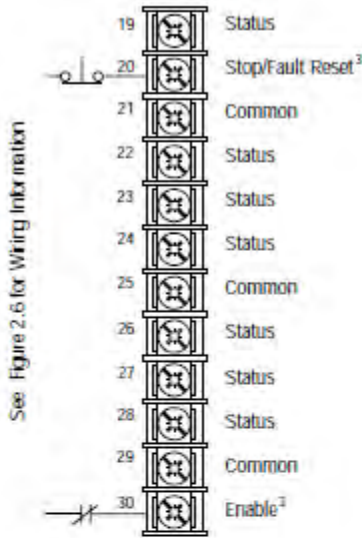
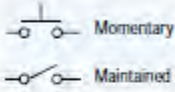

Note: If this mode is selected, the status of all inputs can be read at the [Input Status] parameter. However, only "Stop/Fault Reset" and "Enable" will have control function.

[Input Mode] 2-6, 17, 18, 22
Three-Wire Control with Single-Source Reversing

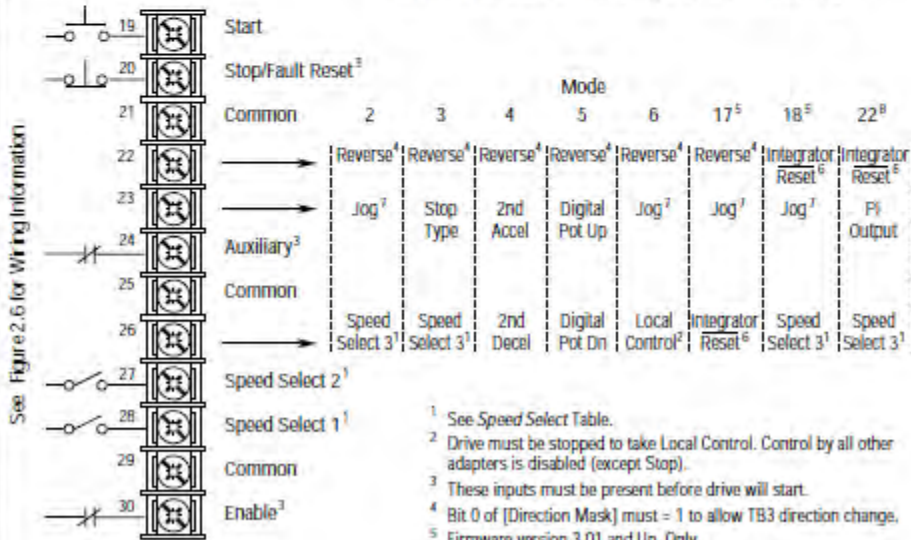

- ¹ See Speed Select Table.
- ² Drive must be stopped to take Local Control. Control by all other adapters is disabled (except Stop).
- ³ These inputs must be present before drive will start.
- ⁴ Bit 0 of [Direction Mask] must = 1 to allow TB3 direction change.
- ⁵ Firmware version 3.01 and Up, Only.
- ⁶ Inverted function - voltage resets integrator to zero.
- ⁷ See ATTENTION statement on this page.
- ⁸ Firmware version 4.01 and Up, Only.

ATTENTION: The JOG function will not operate properly unless a SCANport option is connected to the drive. To assure proper JOG function, install at least one of the following: 1201-HAP, 1201-HA1, 1201-HA2, 1336-GM1. Applies to 1305 with firmware FRN 2.01 or earlier and 1336 PLUS with Language Module 1336S-EN firmware FRN 1.05 or earlier.



ATTENTION: The JOG function will not operate properly unless a SCANport option is connected to the drive. To assure proper JOG function, install at least one of the following: I201-HAP, I201-HA1, I201-HA2, I336-GM1. Applies to I305 with firmware FRN 2.01 or earlier and I336 PLUS with Language Module I336S-EN firmware FRN 1.05 or earlier.



See Figure 2.6 for Wiring Information

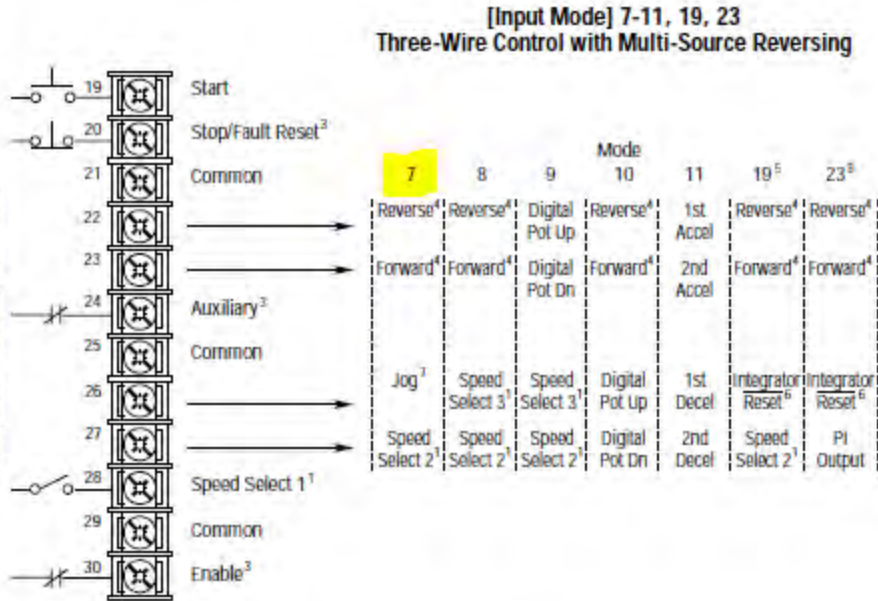

[Input Mode] 12-16, 20, 21, 24
Two-Wire Control, Single-Source Control

See ATTENTION statement below



See Figure 2.6 for Wiring Information

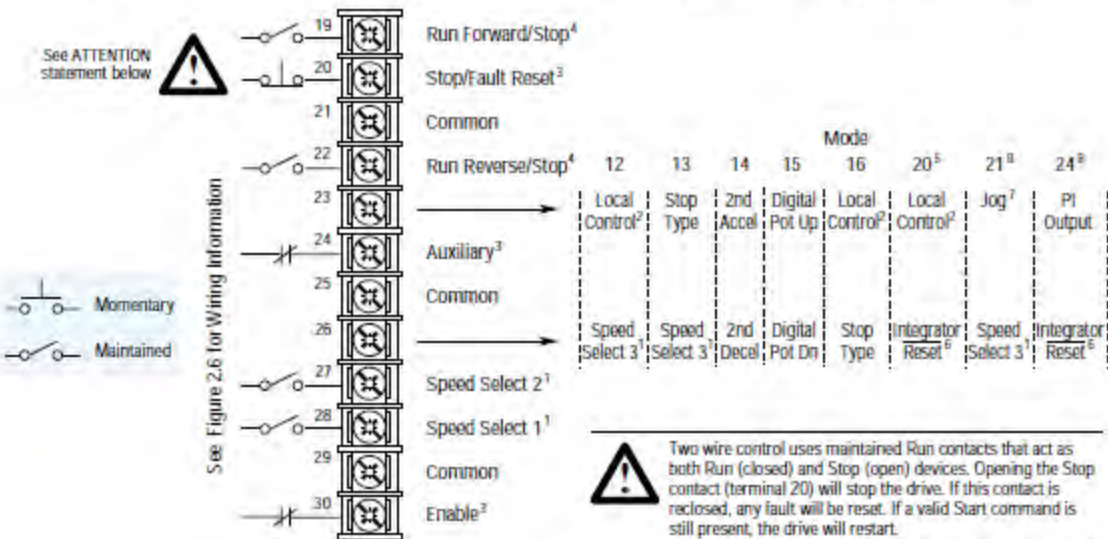

Two wire control uses maintained Run contacts that act as both Run (closed) and Stop (open) devices. Opening the Stop contact (terminal 20) will stop the drive. If this contact is reclosed, any fault will be reset. If a valid Start command is still present, the drive will restart.







If a three wire device (i.e. HIM) is also used, pressing the HIM Stop key will also stop the drive. Releasing the Stop key will clear any faults that are present, but the drive will not restart without cycling the Start contact.

IN THE 1336PLUS THE INPUT MODE WILL BE A NUMERIC VALUE SAY FOR THEORETICAL PURPOSES IT IS THREE WIRE CONTROL WITH A VALUE OF "7". THIS CHOICE IS SHOWN ABOVE AND HIGHLIGHTED. THIS SELECTION GIVES THE FOLLOWING TERMINAL DESIGNATIONS:

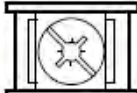
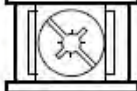
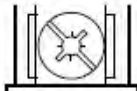
<u>TERMINAL</u>	<u>FUNCTION</u>
22	FORWARD
23	REVERSE
26	JOG
27	SPEED SEL 2

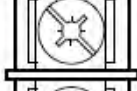
THIS IS A MAJOR DIFFERENCE BETWEEN A 1336S(PLUS DRIVE) AND A 1336F(PLUSII DRIVE). LET'S LOOK AT THE SAME TABLE FOR INPUT MODE IN A 1336PLUSII DRIVE

Figure 2.3
Digital I/O Default Settings – TB3

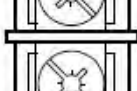
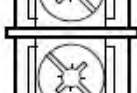
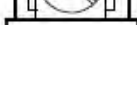
		Input Mode (Start/Stop Functions Only)			
		Status² (Factory Default)	2-Wire Control Single-Source Control	3-Wire Control Single-Source Reversing	
Input 1	19		Status	Run Forward	Start
Input 2	20		Stop/Fault Reset ³	Stop/Fault Reset ³	Stop/Fault Reset ³
		Factory Default Inputs			
Common	21		Status Only Default Mode shown at right is not active when [Input Mode] is set to "Status"	Common	
Input 3	22			Rev/For ⁴	(Programmable)
Input 4	23			Jog	(Programmable)
Input 5	24			Auxiliary ³	(Programmable)
Common	25			Common	
Input 6	26			Speed Select 3 ¹	(Programmable)
Input 7	27			Speed Select 2 ¹	(Programmable)
Input 8	28			Speed Select 1 ¹	(Programmable)
Common	29			Common	
Input 9	30		Enable ³	Enable ³	(Not Programmable)

THE INPUT MODE HAS BEEN SIMPLIFIED FROM THE PREDECESSOR(1336PLUS) THERE ARE ONLY THREE MODES: STATUS, TWO WIRE AND THREE WIRE.

HOW DOES THIS CORRELATE WITH THE PF750 SERIES DRIVES? LET'S CONTINUE WITH THREE WIRE CONTROL AS THE EXAMPLE. TAKE EXAMPLE OF SOME SPECIAL TERMINALS ON THE 1336PLUS AND 1336PLUSII:

TERMINAL 20 **STOP/CLEAR FAULT**

TERMINAL 24 **AUXILLARY** INPUT

TERMINAL 30 **ENABLE** DRIVE INPUT

ALL THREE OF THESE INPUTS NEED TO HAVE A SOURCE OF POWER AT THE TERMINALS OR THE DRIVE WILL NOT START, THEY HAVE TO BE ALL POWERED TO BE ABLE TO START THE DRIVE PRIOR TO THE START SIGNAL LEADING EDGE.

IF THESE ARE SIMPLY JUMPERED OUT ON THE 1336 DRIVE, YOU WILL NOT BE USING THEM ON THE TERMINAL BLOCK FOR THE PF750 DRIVE. THESE WERE MANDATORY INPUTS ON THE 1336PLUS DRIVES THAT **MAY NOT** BE USED ON THE PF750 SERIES.

CONTROL METHODS FOR PF750 SERIES DRIVES

THERE ARE MANY WAYS TO CONFIGURE THE PF750 DRIVE, LETS EXPLORE PROGRAMMING 3 WIRE CONTROL MANUALLY WITHOUT A STARTUP WIZARD THAT CAN BE USED. BY FAR THE BEST WAY TO CONFIGURE THE DRIVE IS WITH STUDIO5000 OR CONNECTED COMPONENTS WORKBENCH SOFTWARE.

THESE SCREEN SHOTS SHOWN ARE TO GIVE YOU A GENERAL IDEA OF HOW WE NAVIGATE AND PROGRAM DRIVE PARAMETERS.

THE PF750 HAS **PORTS**:

PORT1 – HIM

PORT2&3 – DPI PORT ON MAIN CONTROL BOARD(8 PIN MINI DIN)

PORT4,5,6- BACKPLANE PORTS TO LEFT OF MAIN CONTROL BOARD

PORT7&8 – BACKPLANE ADDITIONAL PORTS USED IN PF755

EVERY MODULE IN A PORT HAS IT'S OWN SET OF PARAMETERS, THEY ARE NOT ALWAYS IN **PORT 0**(MAIN CONTROL BOARD OF DRIVE).

PORTS 7,8



PLEASE NOTE THAT PORTS 7&8 ARE DISABLED BECAUSE IT IS A PF753 THAT DOES NOT SUPPORT 5 BACKPLANE PORTS, ONLY THREE PORTS.

NAVIGATION BETWEEN PORTS

It is always important to know which port is hosting – so if the port is the host this is where you are & viewing on the HIM. See the screenshot below and the host.



Port 4 has a 24VDC I/O card – go to the folders pushbutton on HIM use the blue navigation arrows for left and right and find PORTS tab, use up and down to choose which port you want to navigate to.

ADD THREE WIRE CONTROL



USE THE FOLDER BUTTON AND NAVIGATE TO **PORTS** CHOOSE PORT 0 THE PF750 MAIN CONTROL BOARD. THE START AND STOP COMMANDS RESIDE IN THE DRIVE PORT, SO IT WILL HOST. HIT THE **ENTER** KEY WHICH IS THE **OVAL** BUTTON ON THE HIM.

YOU CAN VIEW THE DEVICE PARAMETERS IN DIFFERENT WAYS WE WILL USE LINEAR LIST IN THIS EXAMPLE, WE HAVE THE PAPER MANUAL AND KNOW PARAMETER 161 IN PORT 00 IS "START".





PRESS THE “**PAR**” SOFT KEY(4TH FROM LEFT BUTTON)

TYPE IN “161” PARAMETER NUMBER FOR THE **START** FUNCTION



PRESS THE [ENTER SOFT KEY](#)(SOFT KEY BELOW DISPLAY)



PRESS THE **EDIT SOFT KEY** FAR RIGHT TO EDIT THE START FUNCTION FOR THREE WIRE CONTROL. YOU WILL BEGIN TO KNOW WHERE YOU ARE AND WHERE YOU NEED TO BE. TIE THE **START** COMMAND TO AN INPUT IN SLOT 4.



CHOOSE PORT 4 WHERE THE INPUT IS PHYSICALLY LOCATED.



CHOOSE **BIT 1** FOR THE INPUT 1 IN PORT 4 MODULE. HIT ENTER.



NOW DI START IN PORT 00 IS TIE TO PORT 4 PARAMETER 1(STATUS BITS) BIT 1. NOTICE THE STATUS LIGHT IS AMBER(WARNING) AND MUST BE FIXED THERE IS A DIGITAL CONFIG ERROR – THREE WIRE START INPUT WITH NO STOP INPUT. THE DRIVE WILL NOT RUN UNTIL THE CONFLICT IS RESOLVED. NOW WE ADD THE DI STOP(PAR 158) TO COMPLETE THE THREE WIRE CONFIGURATION.

PLEASE NOTE MIXING TWO WIRE AND THREE WIRE PARAMETERS WILL ALSO CAUSE THIS WARNING AND MUST BE FIXED TO OPERATE.

LET'S ADD THE STOP BIT TO GET RID OF THE WARNING OR ALARM.



GO TO PORT 00 PARAMETER 158, PORT 00 IS HOSTING RIGHT? CORRECT! NOW ASSIGN THE DI STOP COMMAND TO PORT 4 BIT 0.



EDIT DI STOP



TIE TO PORT 4



FIND STATUS BIT 0 SO THAT THE INPUT 0 CAN BE USED FOR THREE WIRE CONTROL. THE AMBER ALARM LIGHT SHOULD CHANGE COLOR WHEN COMPLETE.



PRESS ENTER WHEN INPUT BIT 0 (STATUS)



DI STOP IS NOW COMPLETE – THE DIG CONFIG ALARM IS GONE AND NOW SHOWS STOP ASSERTED. THE STOP INPUT IS NOT WIRED AND HAS NO VOLTAGE SO THE STOPASSERTED SHOWS ON DISPLAY TILL PORT 4 INPUT 0 HAS VOLTAGE AND IS READY TO RECEIVE A DI START COMMAND. WHEN VOLTAGE IS APPLIED TO INPUT 0 THE STS LIGHT WILL FLASH GREEN FOR “READY”.

INPUT MODE CONVERSION COMPLETE.

TWO WIRE CONTROL USES THE [RUN\(PAR 163\)](#) FUNCTION INSTEAD OF START AND STOP. CLOSE THE RUN INPUT AND THE DRIVE STARTS, OPEN THE DI RUN STOPS THE DRIVE.

NOTE: AVOID MIXING TWO AND THREE WIRE FUNCTIONS!

TWO WIRE COMMAND	THREE WIRE COMMAND	PAR#
DI JOG 1 FORWARD		167
DI JOG 1 REVERSE		168
	DI JOG1	166

SPEED REFERENCE CONVERSION



THE 1336PLUS DRIVE USUALLY RUNS OFF FREQ SEL 1, IN THIS EXAMPLE IT IS RUNNING OFF FROM ADAPTER 1 – THE HIM OR KEYPAD POTENTIOMETER. OBSERVE WHAT YOUR SPEED CONTROL IS POINTED TO IN THE 1336PLUS DRIVE.



GO TO PARAMETER 545 IN PORT 00 OF DRIVE, THIS IS THE EQUIVALENT OF FREQ SELECT 1 IN 1336PLUS DRIVE.

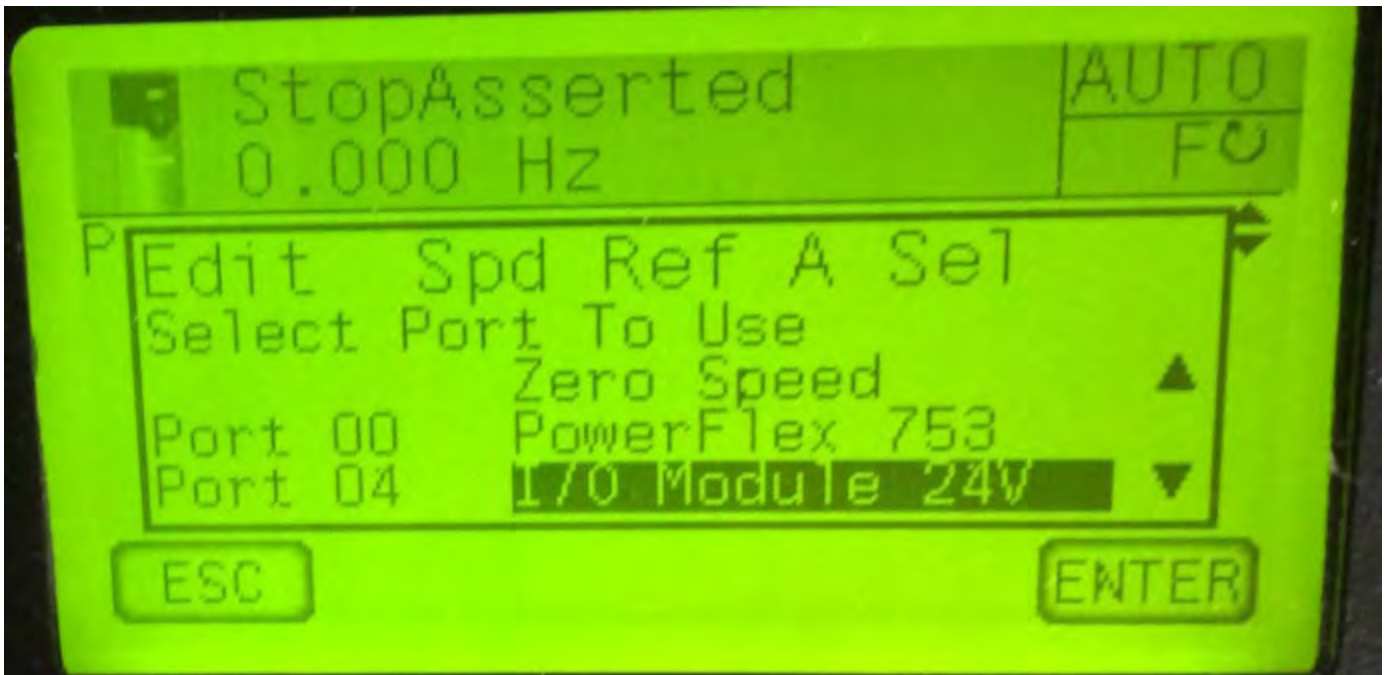

GO TO PORT 4 AND GET AN ANALOG SIGNAL ANLG CHANNEL 0.

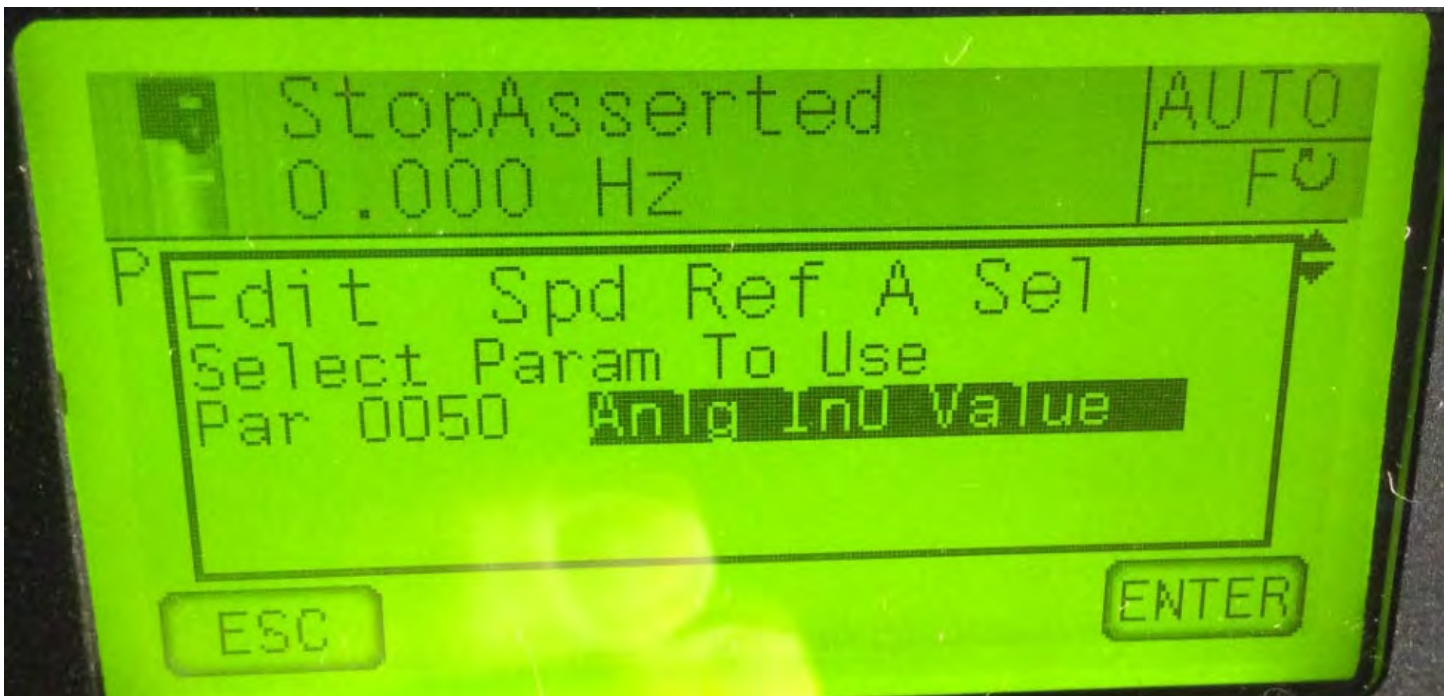

TIE THE ANLG CHANNEL 0 IN PORT 4.



SPEED REF A IS NOW POINTED TO PORT 4 CHANNEL 0. PARAMETER 50 IS THE VALUE THE SPEED REFERENCE IS USING TO GET THE COMMANDED SPEED.

ANALOG OUT CONVERSION

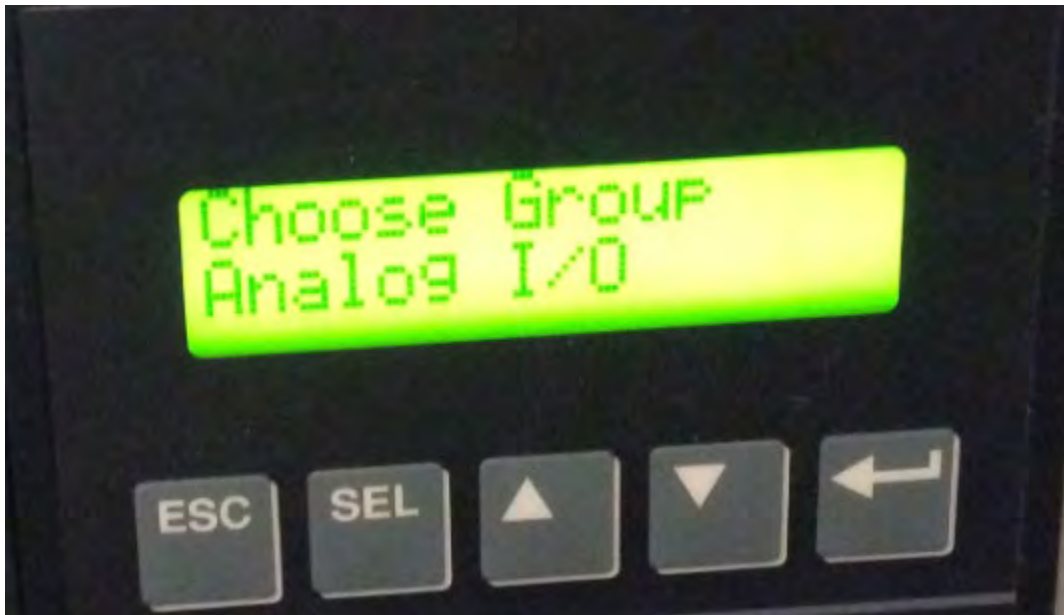

GO TO THE ANALOG I/O GROUP ON 1336PLUS DRIVE.



GO TO ANLG OUT 0 – THE OUTPUT IS TIED TO THE DRIVE “CURRENT” IN 1336PLUS
LET’S MAKE PORT 4 ANLG CHANNEL 0 ON THE PF750 OUTPUT “CURRENT” LIKE
THE 1336PLUS DRIVE.

WE MUST GO TO THE PHYSICAL LOCATION OF THE ANALOG OUTPUT CHANNEL
WHICH IS LOCATED IN PORT 4. USE THE FOLDER PUSHBUTTON ON HIM AND GO
TO PORT 4 TO ACCESS THE CHANNEL.

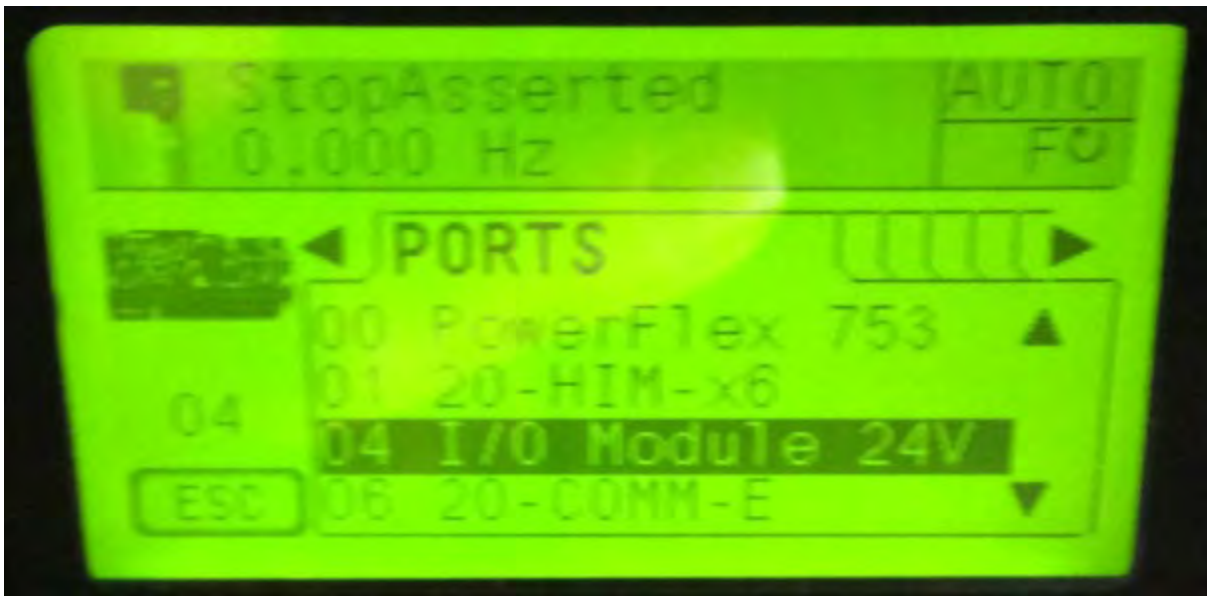

CHOOSE PORT 4



CHOOSE LINEAR LIST AND PRESS THE "5" BLUE ENTER KEY
PORT 4 SHOULD SHOW PARAMETER 1

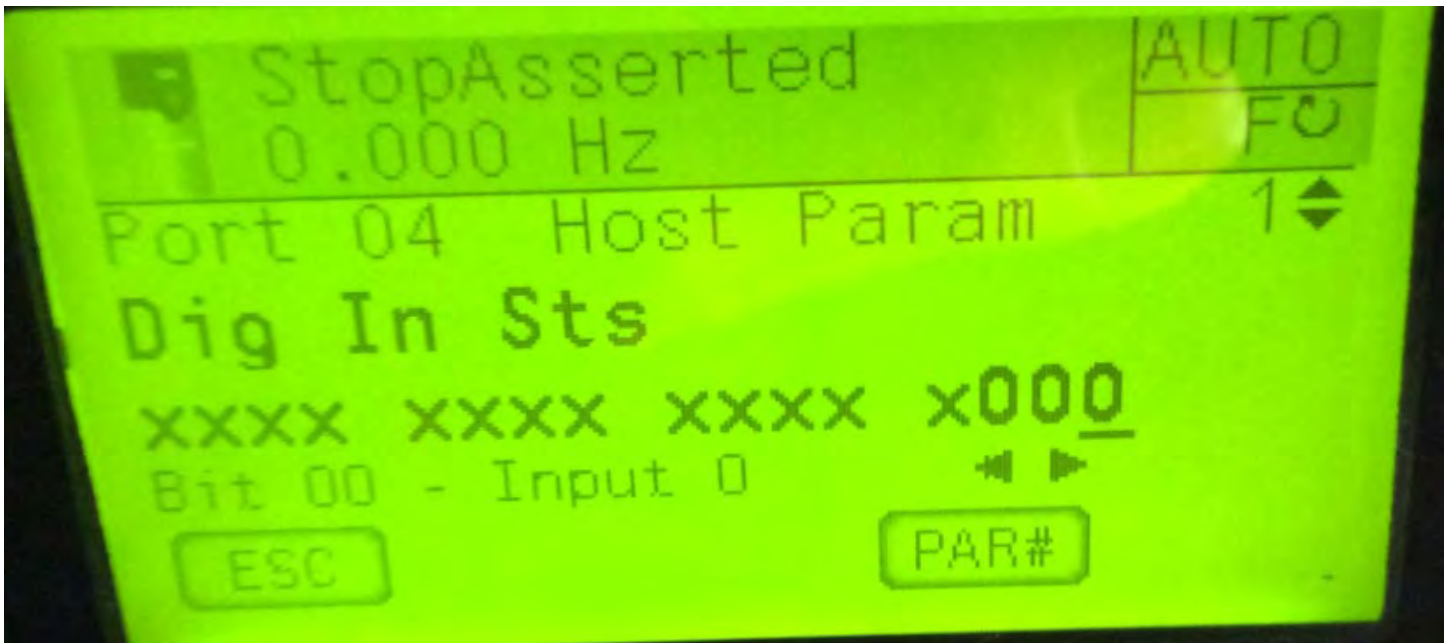

CHOOSE PAR#, YOU KNOW THE PARAMETER BECAUSE YOU HAVE ACCESS TO A PROGRAMMING MANUAL FOR PF750.



GO TO PARAMETER 75 PORT 4 FOR ANLG SEL USE THE SOFT KEY TO EDIT. CHANGE THE SELECT OUTPUT CURRENT.



ANLG OUTPUT TIED TO PAR 7 OUTPUT CURRENT AND SHOULD LOOK LIKE THIS:



ANALOG PARAMETERS OF INTEREST PORT 4 CHANNEL 0: PAR 70-82

Bit	No.	Description
	70	Anlg Out Type Analog Output Type Select the analog output mode for each analog output.
	Options	Reserved Reserved Reserved Reserved Reserved Reserved Reserved Reserved Reserved Reserved Reserved Reserved Reserved Reserved Analog 1 Analog 0
Default	0 0 0 0 0 0 0 0 0 0 0 0 0 0 0 0	0 = Voltage Mode
Bit	15 14 13 12 11 10 9 8 7 6 5 4 3 2 1 0	1 = Current Mode

THE DRIVE FACTORY DEFAULT IS 0-10V ANLG OUT SIGNAL. PLACE A "1" IN EITHER BIT 1 OR BIT 0 OF PARAMETER 70 TO OUTPUT A 4-20 SIGNAL ON EITHER ANLG CHANNEL. THE RESULT WILL BE A 0-20mA SIGNAL.

TO ACHIEVE A 4-20mA SIGNAL THE ANLG OUT LOW NEEDS TO BE CHANGED



DEFAULT FOR ANLG OUT0 LO



PRESS THE EDIT KEY TO CHANGE THE VALUE



CHANGE VALUE TO 4 mA AND PRESS ENTER SOFTKEY AND DONE!

EXPLORING OTHER COMMON PARAMETERS

Setup	Advanced Setup
Page 6–8	Page 6–12
Input Mode (241)	Minimum Freq (16)
Freq Select 1 (5)	Maximum Freq (19)
Accel Time 1 (7)	PWM Frequency (45)
Decel Time 1 (8)	Accel Time 2 (30)
Minimum Freq (16)	Decel Time 2 (31)
Maximum Freq (19)	Sync Time (307)
Stop Select 1 (10)	Stop Select 1 (10)
Current Limit (36)	DC Hold Time (12)
Current Lmt Sel (232)	DC Hold Level (13)
Adaptive I Lim (227)	Hold Level Sel (231)
Current Lmt En (303)	Bus Limit En (11)
Overload Mode (37)	Braking Chopper (314)
Overload Amps (38)	Motor Type (41)
VT Scaling (203)	Stop Select 2 (52)
Motor NP RPM (177)	KP Amps (193)
Motor NP Hertz (178)	Speed Brake En (319) ³
Motor NP Volts (190)	Common Bus (58) ³
Motor NP Amps (191)	

CURRENT LIMIT – CHECK THE 1336PLUS FOR THE VALUE IN SETUP GROUP SHOWN ABOVE.



THIS VALUE IS RARELY CHANGED BUT GOOD TO CHECK THIS IS VALUE. THIS PARAMETER IS TIED TO CURRENT LIMIT SEL SHOWN BELOW IN 1336 DRIVE.



MOTOR DATA INFORMATION

MOTOR DATA MUST BE DOCUMENTED FROM THE 1336PLUS TO THE PF750

MOTOR DATA INFORMATION

SETUP GROUP 1336PLUS

1336PLUS	PAR#	POWERFLEX 750	PAR#
MOTOR RPM	177	MOTOR RPM	28
MOTOR HZ	178	MOTOR HZ	27
MOTOR VOLTS	190	MOTOR VOLTS	25
MOTOR AMPS	191	MOTOR AMPS	26
		MOTOR POLES	31

V/HZ MOTOR CONTROL

PLEASE NOTE 1336PLUS DRIVE PRIOR TO FRN 4.xx WERE V/HZ. SENSORLESS VECTOR WAS FRN 4.xx AND ABOVE. THE 1336PLUS AND 1336PLUSII DID NOT HAVE TUNING CAPABILITIES, THE 1336IMPACT DID HAVE TUNING CAPABILITIES.

PUMPS AND FANS CAN RUN IN V/HZ, IN THIS CASE THE PF750 DRIVE DOES NOT NEED TO BE TUNED. PLEASE KEEP IN MIND THE “AUTOBOOST” THAT SVC GIVES YOU DYNAMICALLY DOES NOT HAPPEN IN V/HZ. YOU WOULD NEED TO ADJUST THE BOOST MANUALLY THROUGH THE PARAMETERS IN DRIVE.

SENSORLESS VECTOR MOTOR CONTROL

SVC CONTROL GIVES DYNAMIC BOOSTING TO THE MOTOR. WHEN THE MOTOR SLOWS DOWN DUE TO A CHANGE IN LOAD THE DRIVE SENSES THE COUNTER EMF OF THE MOTOR. THIS COUNTER ELECTRO MAGNETIC FORCE IS PROPORTIONAL TO THE SPEED OF THE MOTOR. THE DRIVE INCREASES CURRENT TO AVOID THE MOTOR FROM REACHING A STALL CONDITION OR AN ERROR BETWEEN COMMANDED AND ACTUAL SPEED.

SVC OUT OF THE BOX WILL GIVE YOU 1336PLUS DRIVE PERFORMANCE, IF YOU REQUIRE MORE PERFORMANCE THAN THIS PLEASE UNCOUPLE THE MOTOR FROM THE LOAD AND PERFORM A ROTATE AUTOTUNE, IF THE LOAD CAN NOT BE RELEASED PERFORM A STATIC AUTOTUNE.

PLEASE CHECK PARAMETER 70 IN PF750 AFTER AN AUTOTUNE TO MAKE SURE THE DRIVE IS IN READY STATE “0” NOT CALCULATE “1”.

PARAMETERS THAT AUTOTUNE AFFECTS:

P73	IR VOLTAGE DROP	VOLTAGE DROP ACROSS MOTOR RESISTANCE
P74	I_{x0} VOLTAGE DROP	INDUCTANCE LEAKAGE THROUGH WINDINGS
P75	FLUX CURRENT	CURRENT CONSUMED BY MAGNETISM OF MOTOR
P621	SLIP RPM @ FLA	ESTIMATED SLIP OF MOTOR

PLEASE NOTE:

ON PUMPS AND FANS HARDWARE OVERCURRENTS MAY OCCUR IF PARAMETER 621 IS **SET TOO HIGH** ON AUTOTUNE. IF THIS IS OCCURRING IN A PUMP OR FAN APPLICATION PLEASE SET P621 TO "0" AND OBSERVE. THIS PARAMETER CAN NOT BE CHANGED TILL AUTOUNE IS AT READY "0". THIS VALUE IS NOT CHANGED WITHOUT AN AUTOTUNE, V/hz MODE DOES NOT CHANGE THIS PARAMETER BECAUSE A TUNE IS NOT REQUIRED.

ADVANCED PARAMETERS

Setup	Advanced Setup
Page 6-8	Page 6-12
Input Mode (241)	Minimum Freq (16)
Freq Select 1 (5)	Maximum Freq (19)
Accel Time 1 (7)	PWM Frequency (45)
Decel Time 1 (8)	Accel Time 2 (30)
Minimum Freq (16)	Decel Time 2 (31)
Maximum Freq (19)	Sync Time (307)
Stop Select 1 (10)	Stop Select 1 (10)
Current Limit (36)	DC Hold Time (12)
Current Lmt Sel (232)	DC Hold Level (13)
Adaptive I Lim (227)	Hold Level Sel (231)
Current Lmt En (303)	Bus Limit En (11)
Overload Mode (37)	Braking Chopper (314)
Overload Amps (38)	Motor Type (41)
VT Scaling (203)	Stop Select 2 (52)
Motor NP RPM (177)	KP Amps (193)
Motor NP Hertz (178)	Speed Brake En (319) ³
Motor NP Volts (190)	Common Bus (58) ³
Motor NP Amps (191)	

PWM FREQUENCY – OBSERVE 1336PLUS FREQ. IT IS ALWAYS GOOD TO KEEP THE CARRIER FREQUENCY AS LOW AS POSSIBLE(2kHz). DO THE SAME IN THE PF750 TO AVOID EXCESSIVE SWITCHING HEAT AND DAMAGE TO MOTOR. THIS IS PARAMETER 38 IN PF750.

STOP SELECT - HOW DO YOU WANT TO STOP THE DRIVE? COAST OR DC BRAKING, OR S-CURVE?

[Stop Select 1]

This parameter selects the stopping mode when the drive receives a valid stop command unless [Stop Select 2] is selected.

Parameter Number	10
Parameter Type	Read and Write
Factory Default	"Coast"
Units	Display Drive
"Coast" 0	Causes the drive to turn off immediately.
"DC Brake" 1	Drive defluxes the motor and then injects DC braking voltage into the motor. Requires a value in both [DC Hold Time] & [DC Hold Level].
"Ramp" 2	Drive decelerates to 0 Hz., then if [DC Hold Time] & [DC Hold Level] are greater than zero the holding brake is applied. If the values equal zero, then the drive turns off. Requires a value in [Decel Time 1] or [Decel Time 2].
"S-Curve" 3	Drive causes S Curve Ramp to 0 Hz in [Decel Time 1] or [Decel Time 2] x 2.
"Ramp to Hold" 4	Drive decelerates to zero Hertz then injects holding brake per [DC Hold Level] (limited to 70% of drive rated amps) until a) a Start command is issued or b) the Enable input is opened.

OBSERVE THE STOP SELECT VALUE ON THE 1336PLUS DRIVE AND GO TO PARAMETER 370 IN PF750 AND DUPLICATE THE SAME FUNCTION IN THE 1336PLUS DRIVE. PLEASE KEEP IN MIND THE DRIVE CAN NOT REGENERATE POWER BACK UP ONTO THE DC BUS IN COAST MODE, IN EVERY OTHER CONTROLLED STOP THERE IS A CHANCE OF BUS OVERVOLTAGE FAULT IN A CONTROLLED STOP MODE IF THE DECEL TIME IS TOO SHORT. THE DECEL TIME IN COAST MODE IS DISABLED AND MAKES NO DIFFERENCE.

BUS LIMIT EN – A VALUE OF "1" ENABLES THE BUS REGULATOR IN THE 1336PLUS DRIVE, IF THE BUS LEVEL RISES TO 110% OF BUS NOMINAL VOLTAGE REDUCES THE DECEL RATE TO SLOW DOWN THE REGEN BACK TO BUS. PARAMETER 372 IN THE PF750 ENABLES THE BUS REGULATOR. THE EQUIVALENT OF THE 1336PLUS BUS LIMIT EN IS A VALUE OF "1" ADJUST FREQUENCY. THE PF750 HAS A MUCH MORE FEATURE RICH BUS REGULATOR, YOU CAN ADJUST GAINS ON THE REGULATOR CHECK OUT PARAMETERS 372-381 IN PROGRAMMING MANUAL OF PF750 PUB # 750-PM001L-EN-P.

UNDER THE BUS REGULATION PARAMETER(288) IN THE FEATURE SELECT GROUP, VERIFY THE REGULATOR IS TRULY ENABLED.

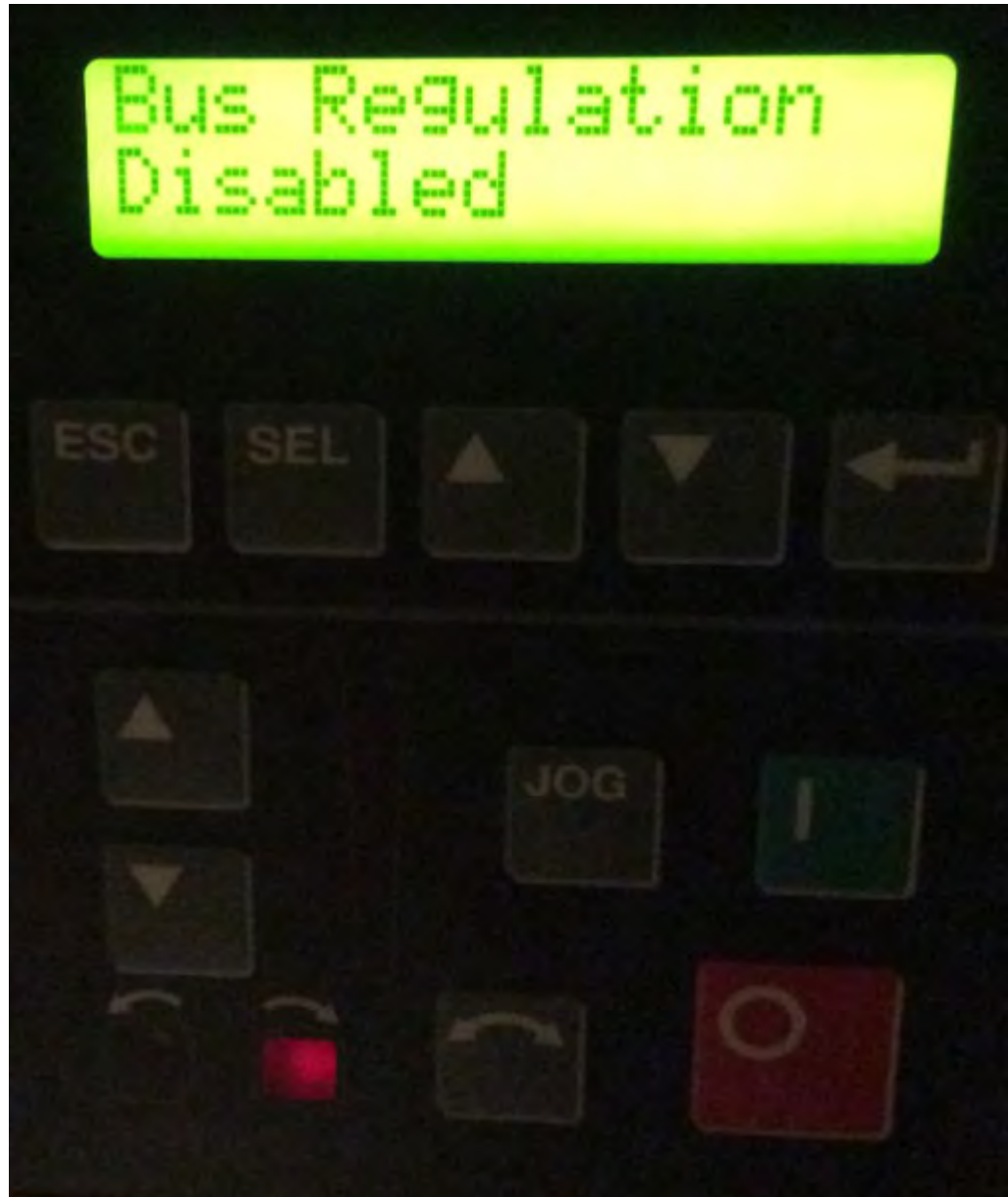

NOW LET MATCH THE BUS REGULATOR SETTINGS IN THE PF750:

GO TO PORT 00 SCREEN AND NAVIGATE TO THE JUMP TO PARAMETER SCREEN TO GET TO THE BUS REGULATOR PARAMETER QUICKLY. KEEP IN MIND IF YOU DON'T LIKE LINEAR LISTS AND PARAMETER #S. CHANGE THE VIEW ON THE PF755 TO VIEW BY GROUPS LIKE THE 1336PLUS. WE WILL USE THE JUMP PROCEDURE FOR THIS EXAMPLE(SHOWN BELOW).

USE THE SOFTKEY FOR PAR# TO DIRECTLY ACCESS THAT PAR NUMBER.



THIS SCREEN SHOULD APPPEAR ENTER "372" TO GO TO THE BUS REG.



HIT THE ENTER KEY WHICH IS THE SOFT KEY ON THE RIGHT.



**PRESS THE EDIT SOFTKEY ON RIGHT SIDE OF THE ROW OF SOFT KEYS
CHANGE THE BUS REGULATOR VALUES TO MATCH THE 1336PLUS DRIVE**

KEEP IN MIND IF THE 1336PLUS HAS A DYNAMIC BRAKE KIT(CHOPPER AND RESISTOR IN ONE PACKAGE) THE PF750 WILL NEED THE BRAKING TRANSISTOR BUILT IN TO THE DRIVE. YOU WILL NEED TO PROVIDE AN EXTERNAL RESISTOR, POSSIBLY USE THE EXISTING ONE OR PURCHASE JUST A RESISTOR AND USE THE BRAKING TRANSISTOR INSIDE THE PF750 DRIVE.

HOW DO WE KNOW THE PF750 HAS A BRAKING TRANSISTOR? THE BRAKING TRANSISTORS ARE AUTOMATICALLY INCULDED UP TO 96 AMPS. WHEN YOU ORDER A PF750 AFTER THE 96 AMP LEVEL IT MUST BE REQUESTED IN THE PART NUMBER, THE 12TH POSITION NEEDS TO BE AN "A" TO GET AN INTERNAL BRAKING RESISTOR UNDER THE HOOD OF DRIVE.

PowerFlex 750-Series Brochure, publication [750-BR001](#)
PowerFlex 750-Series Technical Data, publication [750-TD001](#)
PowerFlex 750-Series Quick Start Guide, publication [750-QS001](#)

Catalog Number Explanation

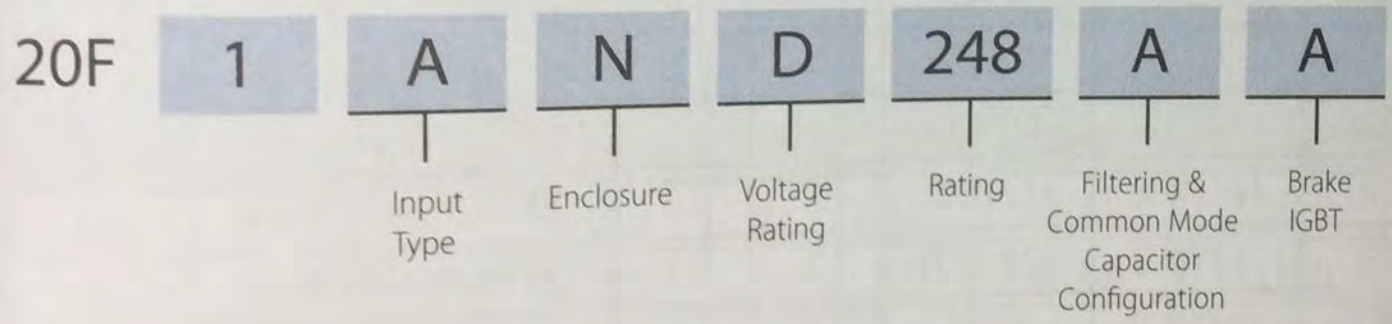

IF POSITION 12 IS AN “N” YOU DO NOT HAVE AN INTERNAL BRAKING RESISTOR. THIS EXAMPLE HAS A BRAKING TRANSISTOR.

REMEMBER IF YOU WANT TO REPURPOSE A RESISTOR MAKE SURE THE RESISTANCE IS ABOVE THE MINIMUM RESISTOR RATING OF THE PF750 DRIVE IN THE TECHNICAL DATA PUBLICATION SHOWN IN ABOVE IMAGE.

REMEMBER THE BUS REGULATOR REGULATES SPEED OR DUMPS TO A DYNAMIC BRAKING RESISTOR FOR TWO REASONS – PREVENT BUS OVERVOLTAGE AND PROVIDE NEGATIVE MOTOR BRAKING TORQUE.

SO WHEN YOU ASK THE BUS REGULATOR TO REACT TO OVERVOLTAGE, THE QUESTION TO ASK IS CAN THE PROCESS BEAR INCREASES THE DECEL TIME SLIGHTLY BY BUMPING THE FREQUENCY ON DECEL OR DOES THE PROCESS NEED TO STOP EXACTLY IN 5 SECONDS?

FLYING START

FLYING START USES A SPEED SEARCH FUNCTION TO DETERMINE WHAT SPEED THE MOTOR IS RUNNING AT WHEN THE DRIVE IS COMMANDED TO START. THE SPEED OF THE ROTATING MOTOR IS MATCHED AND THE DRIVE RUNS AT THE SAME SPEED.

GO TO THE FEATURE SELECT GROUP ON THE 1336PLUS DRIVE

0

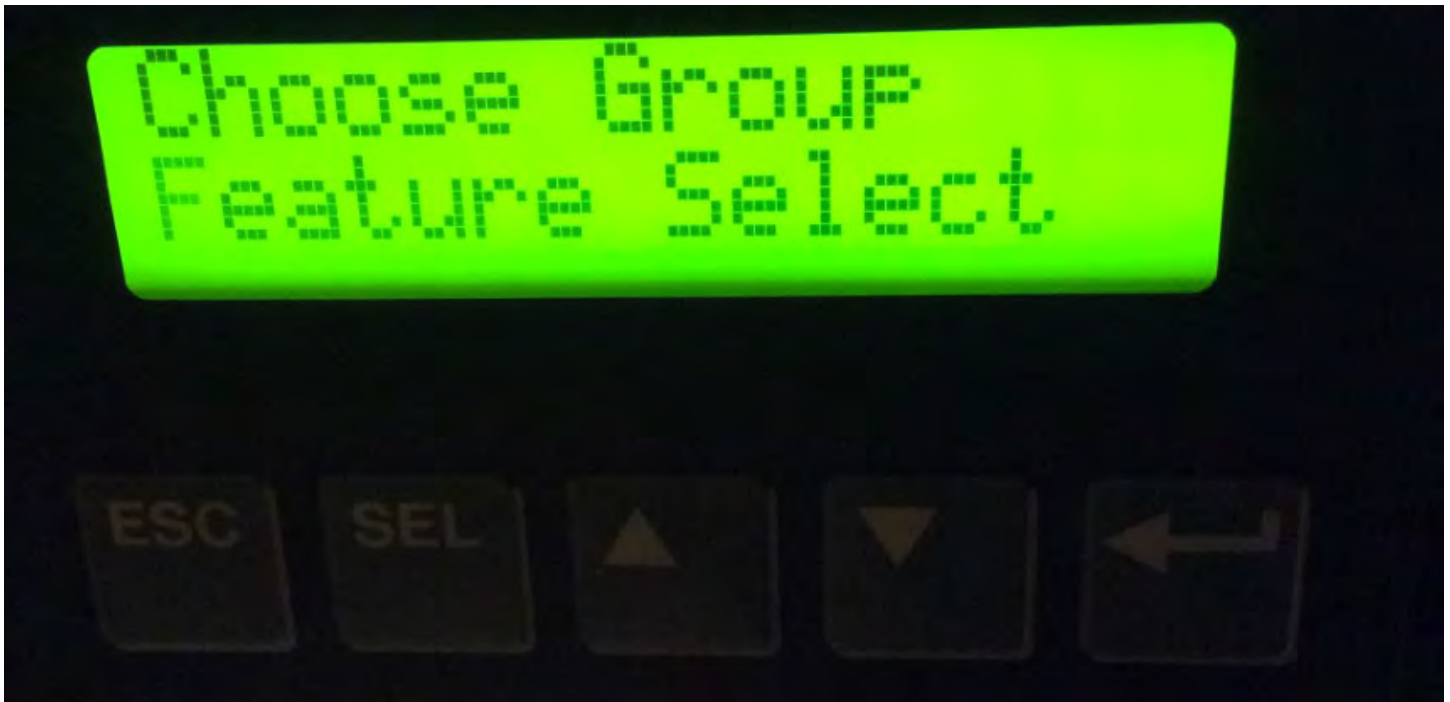

GO TO FLYING START AND SEE IF IT IS ENABLED



SETTING THE FLYING START IN PF750 DRIVE

DRIVE CFG	Start Features		MIN/MAX	0.00 / 0.000			
		356	FlyingStart Mode Flying Start Mode Enables/disables the function which reconnects to a spinning motor at actual RPM when a start command is issued. Functional in all motor control modes. "Enhanced" (1) – This advanced mode performs the reconnect function quickly. "Sweep" (2) – This frequency sweep mode is used with output sine filters.	Default: Options:	0 = "Disabled" 0 = "Disabled" 1 = "Enhanced" 2 = "Sweep" (1) (1) Frames 1...7 only	RW	32-bit Integer

IF THE FLYING START WAS USED IN THE 1336PLUS SET PARAMETER 356 IN PORT 00 OF THE PF750 TO A VALUE OF "1" ENHANCED TO ACTIVATE.

PLEASE KEEP IN MIND WHEN THE SPEED SEARCH FUNCTION IS ACTIVE THE SHAFT ON THE MOTOR AT ZERO SPEED MAY TURN SLIGHTLY BACKWARDS WHEN THE DRIVE STARTS.

THIS CONCLUDES THE MODERNIZATION CONCEPTS FOR BASIC SETUP OF A PF750 DRIVE FROM A 1336PLUS, 1336PLUSII.

